



Volvo Construction Equipment

EWRI50E

Volvo Excavators 15.4-17.9 t 105 kW



A passion for performance

At Volvo Construction Equipment, we're not just coming along for the ride. Developing products and services that raise productivity – we are confident we can lower costs and increase profits for industry experts. Part of the Volvo Group, we are passionate about innovative solutions to help you work smarter – not harder.

Helping you to do more.

Doing more with less is a trademark of Volvo Construction Equipment. High productivity has long been married to low energy consumption, ease of use and durability. When it comes to lowering life-cycle costs, Volvo is in a class of its own.

Designed to fit your needs.

There is a lot riding on creating solutions that are suited to the particular needs of different industry applications. Innovation often involves high technology – but it doesn't always have to. Some of our best ideas have been simple, based on a clear and deep understanding of our customers' working lives.



You learn a lot in 180 years.

Over the years, Volvo has advanced solutions that have revolutionized the use of construction equipment. No other name speaks Safety louder than Volvo. Protecting operators, those around them and minimizing our environmental impact are traditional values that continue to shape our product design philosophy.

We're on your side.

We back the Volvo brand with the best people. Volvo is truly a global enterprise, one that is on standby to support customers quickly and efficiently – wherever they are.

We have a passion for performance.



Volvo Trucks



Renault Trucks



Mack Trucks



UD Trucks



Volvo Buses



Volvo Construction Equipment



Volvo Penta



Volvo Financial Services

Outstanding stability

The EWR150E delivers everything and more that you would expect from a 15 tonne excavator. Work and perform in narrow and confined spaces with the new Volvo short swing radius wheeled excavator, featuring a 1 720 mm short tail dimension. Swing into action with superior performance and stability.

A genuine 15 tonne machine

This addition to the Volvo product portfolio delivers a star performance with ultimate power and stability. With improved lifting capacity compared to a conventional excavator in this class, the new design means you benefit from the short swing radius with no compromise on reach, lifting and digging performance.



Versatility

Volvo offers different types of undercarriage from a 15.2 tonne welded undercarriage with a radial blade and EW140 class drivetrain, up to a 17.8 tonne bolted undercarriage with a parallel blade, bolted outriggers and a EW160 class drivetrain with a 30% higher drawbar pull. Choose from a choice of undercarriage and work equipment, which works and performs for you.



Controllability

Feel at home with smooth operation thanks to the improved hydraulics for added comfort and precise results. Making it easy and improving accuracy, the machine's hydraulic components and controllability increases operator efficiency.





SHORT SWING PERFORMANCE



Take on jobs which a conventional excavator cannot. The short swing radius design means that you can work within a single lane road or confined working space. It also allows the operator to work in greater comfort for ease of operation and increased safety.



BUILT IN PARTNERSHIP



Volvo has included the customer at every stage of the machine's design and manufacture through customer visits and test driving sessions. This means the machine is tailored to customer demands to ensure it performs on your job site.

Designed by you, built by Volvo

Tailored to customers' demands for optimum productivity and profitability, the versatile machine combines power, machine longevity, easy service access and fuel efficiency for an all-round machine in tune with your needs. Get ready to experience ultimate power, increase uptime and make profit.

Passive regeneration

The new intelligent passive regeneration system is working in the background all the time, taking care of itself, to keep you working without having to worry about regeneration and the condition of your machine. This will increase work hours to improve your total cost of ownership.

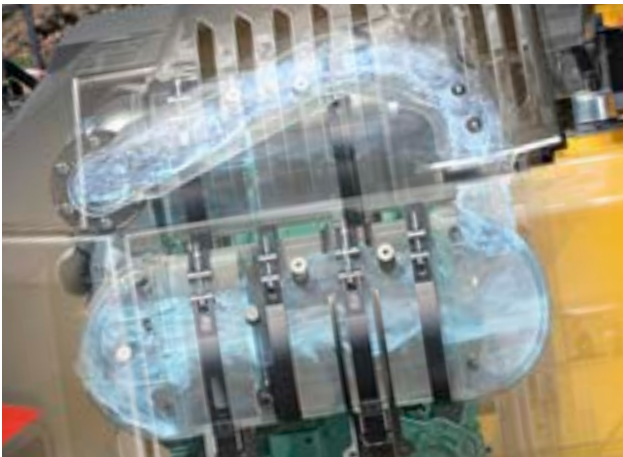

Stage IV engine

Combine power with efficiency. Volvo's efficient diesel engine with V-ACT technology gives you more power and consumes less fuel for high torque at low engine speeds. The efficient engine lowers emission levels to reduce its environmental impact and meet the latest emissions legislation.



Fuel efficiency

The combination of optimized hydraulics system, intelligent Stage IV engine and well matched components, such as ECO Mode, auto idle and auto engine shutdown creates a fuel efficient machine, lowering your running costs and increasing your profitability.



Service access

Service your machine easily and quickly to reduce your downtime. Easy ground level access to grouped service points allows for fast and effortless maintenance and service checks to get you back up and running in no time.



An efficient environment

The EWR150E features the industry leading Volvo cab, which offers great visibility for safe operation. Ergonomically designed controls for added convenience and more in-cab space with multifunctional features, provide a comfortable and efficient operator environment.

HMI

Get to grips with the machine's controls as all machine interfaces – including the joysticks, keypad and large LCD monitor – are ergonomically positioned and designed for optimum control and efficiency. For operator convenience and ease of use, the number of switches has been significantly reduced.



Volvo Smart View

Three optional cameras attached to three different corners of the machine – front, side and back – combine to create a bird's eye view of the machine operating from above. The cameras also provide individual views of the machine so you can see all angles and ensure safe rotation. This intelligent and industry leading technology offers a 360° view of real footage happening in real time.



Operator convenience

Operate in comfort every day with a number of features that together, deliver greater operator convenience for a more comfortable and productive environment, including drawer type tool box, trailer hitch, refuelling pump, in-cab fluid check, short cut button and Bluetooth.



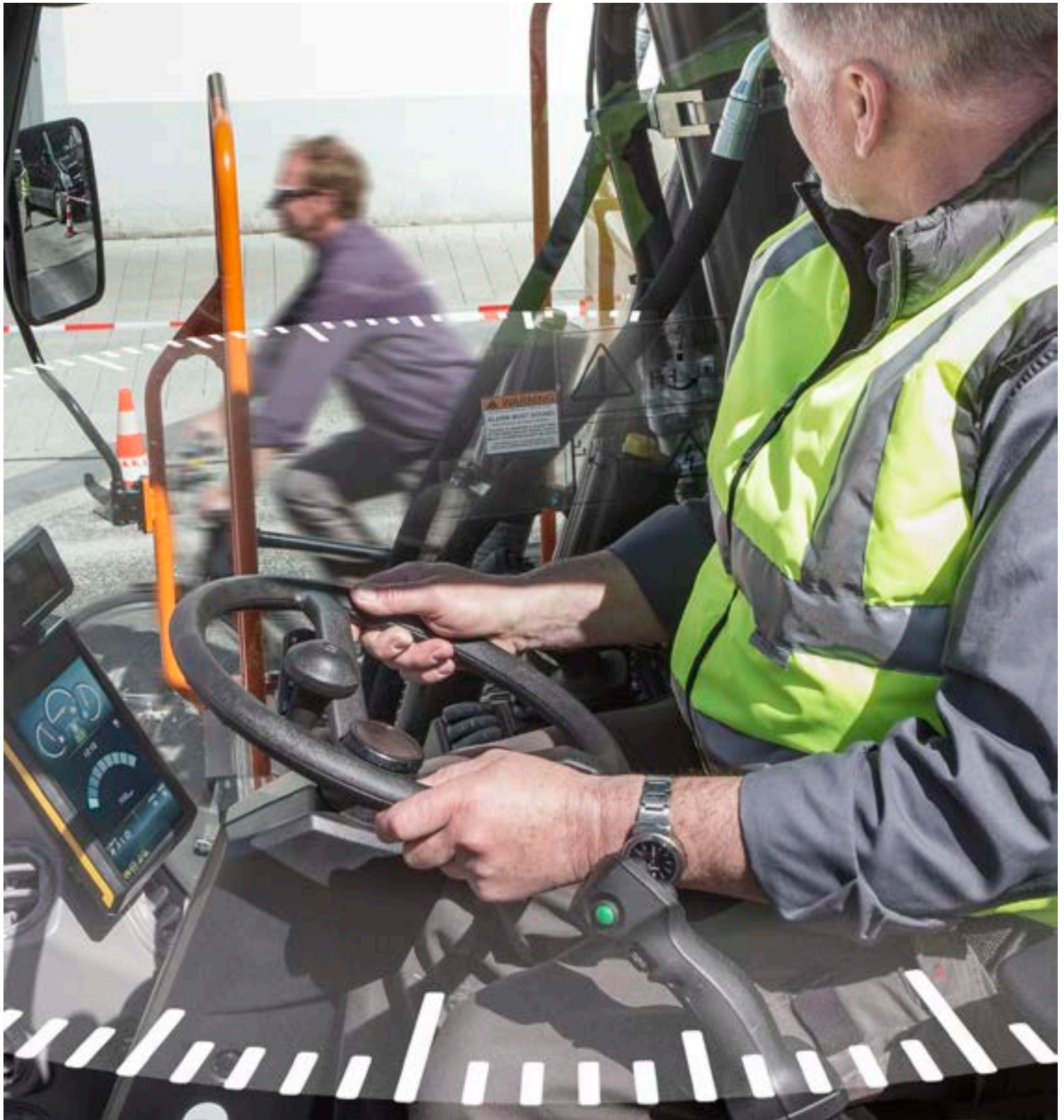

VISIBILITY



A low superstructure and the engine positioned at the back of the machine create an unobstructed view to the right of the machine to clearly see pedestrians and obstacles. The large front and side glass windows of the cab also increase operator visibility.



TILTROTATORS



Steelwrist® tiltrotators provide a superior tilt angle for greater flexibility with maximum strength and durability. The compact design boasts the lowest build height on the market –resulting in improved digging performance and higher fuel efficiency. Steelwrist® is a registered trademark of Steelwrist AB

Rotate your attachments

A wide range of easy-to-fit attachments can save you time, reduce costs and create a multi-functional machine. With Steelwrist® tiltrotators, lightweight quick couplers, durable buckets and breaker, the EWR150E can not only work in tight spaces, but it can dig, load, break and move material in the most efficient and productive way.

Quick couplers

Make it easy on the job and switch between attachments with either the S6 or S60 Quick Couplers. The S60 is a lightweight, cast quick coupler with a low build height and Front Pin Lock technology, which provides a tight, shim-free fit.



Buckets

Select from a range of original Volvo buckets made to work in harmony with your Volvo excavator. Buckets are available as direct-fit or with Volvo quick coupler interfaces. The GPX, TGX and CAX buckets are specifically designed to work with the tiltrotator.



Attachment Management System

The password protected attachment management system allows storage for up to 20 different attachments. The system lets the operator pre-set hydraulic flow and pressure inside the cab through the monitor, which ensures the use of various attachments for increased versatility.

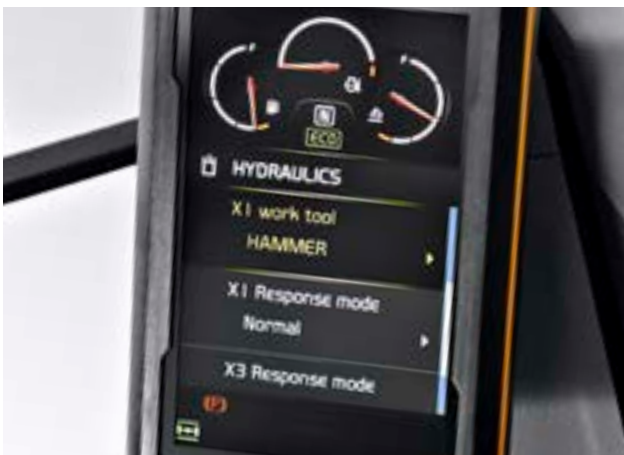

Breaker

The Volvo hydraulic breaker is designed and optimized to work with the specific weights of Volvo machines and is tailored to Volvo quick couplers for swift, safe and simple attachment changes. The HB15 is available with a full assortment of tools.



In a class of its own

VISIBILITY



A low superstructure and the engine positioned at the back of the machine create an unobstructed view of obstacles.

Passive regeneration

The passive regeneration system works in the background, to keep you working without having to worry about the condition of your machine.

TILTROTATORS



Steelwrist® tiltrotators provide a superior tilt angle for greater flexibility with maximum strength and durability.

BUILT IN PARTNERSHIP



Volvo has included the customer at every stage of the machine's design and manufacture through customer visits and test driving sessions.

Made in Germany

Designed, made and tested in Germany the EWR150E wheeled excavator is perfect for use anywhere in the world.



Volvo Smart View

Optional cameras attached to three different corners of the machine combine to create a bird's eye view of the machine operating from above.

AdBlue®

Volvo offers a total AdBlue solution that is quality assured, cost efficient and easily accessible. Contact your Volvo dealer for more information. ® = registered trademark of the Verband der Automobilindustrie e.V. (VDA)

SHORT SWING PERFORMANCE

The short swing radius design, with 1720 mm short tail dimension, means that you can work within a confined space in greater comfort for ease of operation and increased safety.

Stage IV engine

Volvo offers an efficient diesel engine with V-ACT technology for higher torque at lower speeds, resulting in lower fuel consumption.

Service access

Easy ground level access to grouped service points allows for fast and effortless maintenance and service checks.

CUSTOMER SUPPORT AGREEMENTS

Customer Support Agreements offer preventive maintenance, total repairs and a number of uptime services.

Trailer towing hitch

For maximum versatility and productivity, take all your tools to the job site on one trip using the trailer hitch.



Adding value to your business

Being a Volvo customer means having a complete set of services at your fingertips. Volvo can offer you a long-term partnership, protect your revenue and provide a full range of customer solutions using high quality parts, delivered by passionate people. Volvo is committed to increasing the positive return on your investment and maximising uptime.



Complete Solutions

Volvo has the right solution for you. So why not let us provide all your needs throughout the whole life cycle

of your machine? By listening to your requirements, we can reduce your total cost of ownership and increase your revenue.



Genuine Volvo Parts

Our attention to detail is what makes us stand out. This proven concept acts as a solid investment in your machine's future. Parts are extensively tested and approved because every part is vital for uptime and performance. Only by using Genuine Volvo Parts, can you be sure that your machine retains the renowned Volvo quality.



Service Network

In order to respond to your needs faster, a Volvo expert is on the way to your job site from one of our Volvo facilities. With our extensive infrastructure of technicians, workshops and dealers, Volvo has a comprehensive network to fully support you using local knowledge and global experience.





CUSTOMER SUPPORT AGREEMENTS



The range of Customer Support Agreements offer preventive maintenance, total repairs and a number of uptime services. Volvo uses the latest technology to monitor machine operation and status, giving you advice to increase your profitability. By having a Customer Support Agreement you are in control of your service costs.

EWR150E in detail

Engine

Volvo Construction Equipment is ready to comply with the tough new EU Stage IV legislation for off-road vehicles with the introduction of a cascade of innovations in its new generation engines with Volvo Advanced combustion technology (V-ACT).

Volvo machines are equipped with in-line turbo charged diesel engine with high pressure unit injector system. The engine features a externally cooled exhaust gas re-circulation (E-EGR), a Diesel Particulate Filter (DPF) and a Selective Catalytic Reduction(SCR) with AdBlue.

Engine	Volvo	D4J
Power out at	r/min	2 000
Gross (ISO 14396)	kW	105
	hp	143
Net (ISO 9249, DIN 6271)	kW	102
	hp	139
Max. torque	N m	605
at engine speed	r/min	1 500
No. of cylinders		4
Displacement	l	4.04
Bore	mm	101
Stroke	mm	126

Electrical System

High-capacity electrical system that is well protected. Waterproof double-lock harness plugs are used to secure corrosion-free connections. The main relays and solenoid valves are shielded to prevent damage. The master switch is standard.

Voltage	V	24
Battery	V	2 x 12
Battery capacity	Ah	2 x 100
Alternator	V/A	24/120
Alternator rating	W	3 360

Undercarriage

Drive train: A variable axle piston motor in combination with a power shift gearbox supplies 3 speeds. The gearbox distributes the energy via propeller shafts to the axles.

2 different undercarriages : a) Welded radial blade only with EW140 drive train. b) Bolted undercarriage with parallel blade with EW160 drivetrain and the option to add outriggers .

Wheels: Alternative single and twin wheels available.

Front axle: Robust excavator axle with automatic or operator controlled front axle oscillation lock.

Oscillating	± °	9
with mudguards	± °	6
Twin wheels		10.00/11.00-20
Tractive force (net)	kN	88 / 111
Travel speed, on road	km/h	20.0 / 30.0 / 35.0
Travel speed, off road	km/h	5.0 / 8.5
Travel speed, creep	km/h	3
Min. turning radius	m	7.3

Cab

New design Volvo Care Cab with operator protective structure, large and roomy interior. One way travel pedal with rocker switch control (F-N-R) on the right joystick. One-touch release for digging brake pedal. Audio system with remote control and Bluetooth system for hands free phoning. Independently adjustable joystick consoles.

Excellent all-round visibility provided by maximized cab class, transparent roof hatch, 2-piece sliding door window and long stroke, easy to adjust and new narrow steering column. The liftable front windshield can easily be stored in the inside roof space and clipped in position. The removable lower front glass can be stored in the side door pocket. Interior lighting consists of one reading light and one light with timer.

The pressurized and filtered cab air is supplied by a 14-vent climate-control providing fast defrosting and high cooling and heating performance. Viscous/spring mounted suspension cushions protect the operator from vibrations. Deluxe air-suspension seat with adjustable seat suspension, height, tilt, recline and forward-backward settings.(option)

Adjustable, easy to read 8.3" LCD color monitor provides real time information of machine functions and important diagnostic information and is switchable to rear view camera monitor(standard) / side view camera (option) .A new multi function button on left hand joystick with programmable function to improve the operator comfort.

Sound Level

In cab, acc. to ISO 6396		
LpA	dB(A)	71
External, acc. to ISO 6395 and Directive 2000/14/EC		
LwA	dB(A)	100

Hydraulic System

Closed-centre load sensing hydraulic system with pressure compensated valves. Load independence of movements. Flow sharing feature, combined with a high flow pump (power regulation). The system gives superior manoeuvrability and fast movements, for optimal working result and economy.

The following working modes are included in the system:

Parking mode (P): Parking position for optimal safety.

Travel mode (T): Engine speed is controlled by travel pedal stroke for low fuel consumption and noise.

Working mode (W): Full working flow with adjustable engine rpm for normal working and best speed utilisation.

Customer mode (C): Operator can set proper oil flow in accordance with job conditions.

Power Boost: All digging and lifting forces are increased.

Hydraulic pumps:

Main pump (type low noise axial piston pump)		
Max. flow	l/min	275
Brake + steering pump (type low noise gear pump)		
Max. flow	l/min	31
Attachment circuit		
Max. flow	l/min	239
Max. pressure:		
Implements	MPa	32.5 / 36
Travel system	MPa	36
Pilot system	MPa	3.5

Brake System

Service brakes: servo-hydraulically manoeuvred self-adjusting wet multidiscs with two separate brake circuits.

Parking brake: negative wet disc in gear housing, spring applied and pressure released.

Digging brake: service brake with mechanical lock system.

Security system: The 2-circuit travel brakes are supplied with two accumulators in the event of failure in the service brake system.

Service Refill

Fuel tank	l	200
AdBlue tank	l	25
Hydraulic system, total	l	230
Hydraulic tank	l	104
Engine oil	l	16
Engine coolant	l	16
Transmission	l	2.5
Axle differential:		
Front axle	l	9.5
Rear axle	l	12.5
Final drive, wet disc type	l	4 x 2.5

Slew System

The superstructure is slewed by the means of a radial piston motor without reduction gear.

Automatic slew holding brake and anti-rebound valve are standard.

Max. slew speed	r/min	9
-----------------	-------	---

Total Machine Weights

Machine with 4.5 m monoblock boom, 2.45 m dipper arm, quickfit S6, 410 kg / 580 l bucket.		
Welded radial dozer blade front and outriggers rear	kg	16 500
Welded radial dozer blade rear only	kg	15 400
Bolted dozer blade front and outriggers rear	kg	17 400
Bolted dozer blade rear only	kg	16 300
Machine with 4.7 m 2-piece boom, 2.45 m dipper arm, quickfit S6, 410kg / 580 l bucket.		
Welded radial dozer blade front and outriggers rear	kg	17 000
Welded radial dozer blade rear only	kg	15 900
Bolted dozer blade front and outriggers rear	kg	17 900
Bolted dozer blade rear only	kg	16 800

Specifications

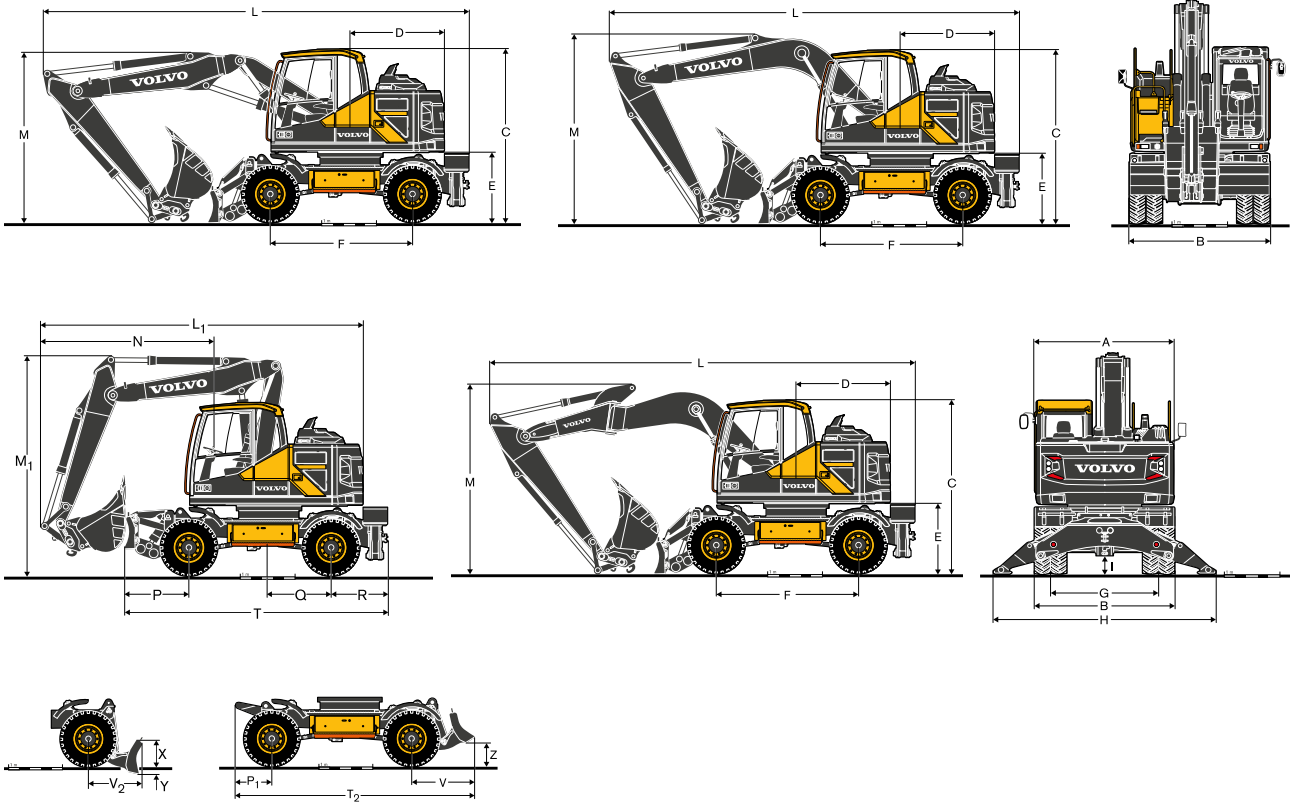

DIMENSIONS

Description	Unit	Mono boom				2-piece boom				Mono offset boom		
	m	4.5				4.7				4.75		
A Overall width of superstructure	mm	2 520				2 520				2 520		
B Overall width	mm	2 540				2 540				2 540		
C Overall height of cab	mm	3 150				3 150				3 150		
D Tail slew radius	mm	1 720				1 720				1 720		
E Counterweight clearance	mm	1 260				1 260				1 260		
F Wheel base	mm	2 600				2 600				2 600		
G Tread	mm	1 940				1 940				1 940		
H Outrigger width (front or rear)	mm	3 990				3 990				3 990		
I Min. ground clearance	mm	340				340				340		
Description	Unit	Mono boom				2-piece boom				Mono offset boom		
	m	4.5				4.7				4.75		
	m	Arm				Arm				Arm		
		2.0	2.45	2.6	3.1	2.0	2.45	2.6	3.1	2.0	2.45	2.6
L Overall length	mm	7 640	7 500	7 560	7 570	7 830	7 760	7 790	7 640	7 880	7 850	7 860
M Overall height of boom	mm	2 950	3 330	3 320	3 320	2 730	3 080	3 040	3 420	2 890	3 260	3 300
L ₁ Overall length	mm	-	-	-	-	6 460	6 570	6 610	5 740*	-	-	-
M ₁ Overall height of boom	mm	-	-	-	-	3 960	3 970	3 970	3 980**	-	-	-
N Front overhang	mm	-	-	-	-	3 050	3 150	3 190	2 330**	-	-	-

** without bucket

UNDERCARRIAGE DIMENSIONS

Description	Unit	Welded undercarriage with radial blade		Bolted undercarriage with parallel Blade	
P	mm	1 150		1 180	
P ₁	mm	675		750	
Q	mm	1 150		1 150	
R	mm	1 030		1 030	
T	mm	4 790		4 810	
T ₂	mm	4 440		4 470	
V	mm	1 160		1 120	
V ₂	mm	940		920	
X	mm	460		450	
Y	mm	180		150	
Z	mm	400		520	

Specifications

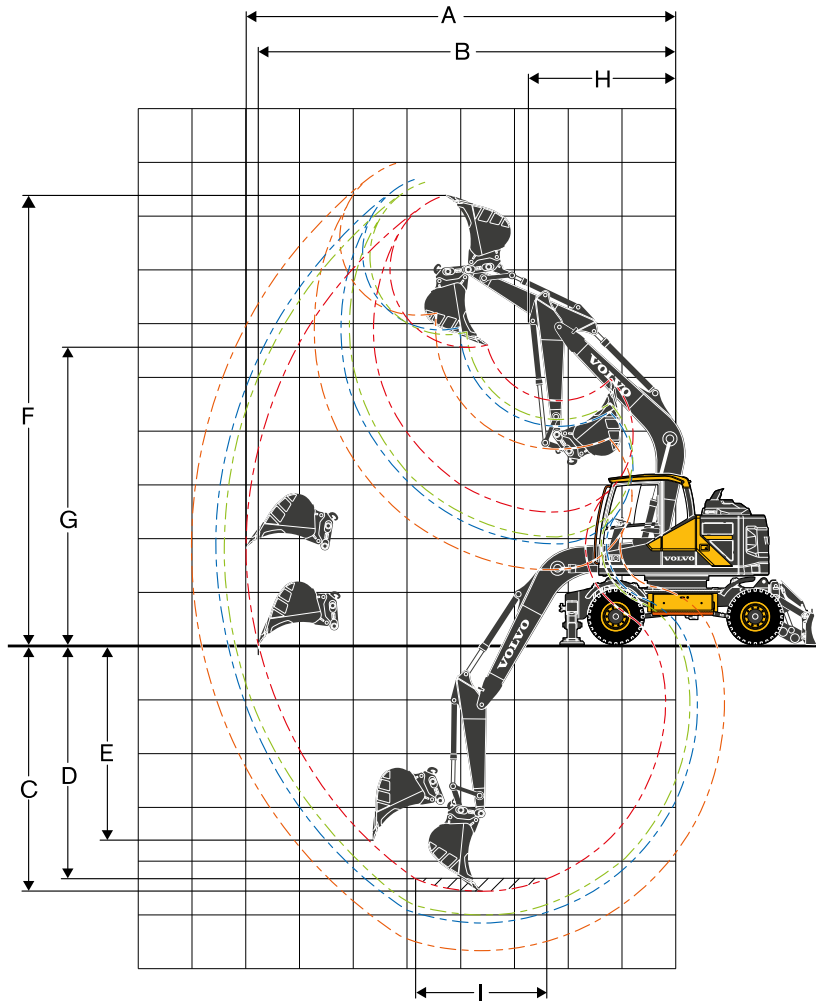

Mono boom 4.5 m and dipper arm 2.0 m, 2.45 m, 2.6 m, 3.1 m

WORKING RANGES & DIGGING FORCES

Description	Unit	Mono boom				
		4.5				
		Arm				
		2.0	2.45	2.6	3.1	
A	Max. digging reach	mm	7 980	8 400	8 540	9 010
B	Max. digging reach on ground	mm	7 770	8 200	8 340	8 820
C	Max. digging depth	mm	4 610	5 070	5 210	5 710
D	Max. digging depth (l = 2.44 m level)	mm	4 380	4 870	5 050	5 550
E	Max. vertical wall digging depth	mm	3 670	4 100	4 250	4 770
F	Max. cutting height	mm	8 320	8 560	8 640	8 910
G	Max. dumping height	mm	5 500	5 740	5 820	6 090
H	Min. front slew radius	mm	2 740	2 740	2 750	2 730
Digging forces with direct fit bucket						
	Breakout force - bucket (ISO)	kN	108.5*	108.5*	108.5*	108.5*
	Tearout force (ISO)	kN	73*	63.5*	61*	53.5*
Max. recommended sizes for direct fit buckets						
	GP-Bucket (1.8 t/m ³)	l	730	730	730	730
Max. recommended sizes for quick fit buckets						
	S6/S60 QF GP-Bucket (1.8 t/m ³)	l	730	730	730	730
	S6 QF HD-Bucket (2.1 t/m ³)	l	520	520	520	520
	UQF GP-Bucket (1.8 t/m ³)	l	730	730	730	660

*with Power boost

Note: 1. Bucket size based on SAE-J296, heaped material with a 1:1 angle of repose. 2. "Max permitted sizes" are for reference only and are not necessarily available from the factory.

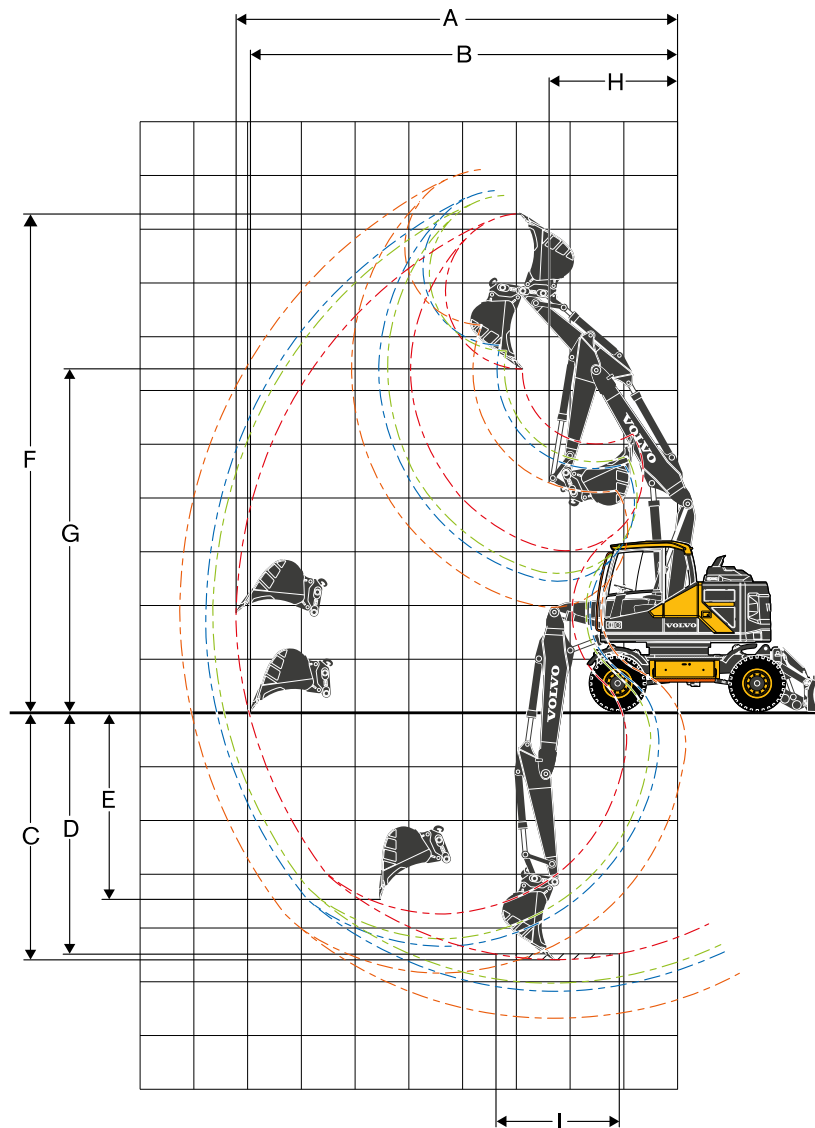

2-piece boom 4.7 m and dipper arm 2.0 m, 2.45 m, 2.6 m, 3.1 m

WORKING RANGES & DIGGING FORCES

Description	Unit	2-piece boom				
		4.7				
		Arm				
		2.0	2.45	2.6	3.1	
A	Max. digging reach	mm	8 240	8 670	8 810	9 300
B	Max. digging reach on ground	mm	8 040	8 470	8 620	9 110
C	Max. digging depth	mm	4 650	5 100	5 240	5 740
D	Max. digging depth (l = 2.44 m level)	mm	4 530	5 000	5 140	5 640
E	Max. vertical wall digging depth	mm	3 520	4 000	4 100	4 600
F	Max. cutting height	mm	9 220	9 560	9 670	10 030
G	Max. dumping height	mm	6 340	6 670	6 780	7 150
H	Min. front slew radius	mm	2 440	2 560	2 600	2 740
Digging forces with direct fit bucket						
	Breakout force - bucket (ISO)	kN	108.5*	108.5*	108.5*	108.5*
	Tearout force (ISO)	kN	73*	63.5*	61*	53.5*
Max. recommended sizes for direct fit buckets						
	GP-Bucket (1.8 t/m ³)	l	730	730	730	730
Max. recommended sizes for quick fit buckets						
	S6/S60 QF GP-Bucket (1.8 t/m ³)	l	730	730	730	580
	S6 QF HD-Bucket (2.1 t/m ³)	l	520	520	520	520
	UQF GP-Bucket (1.8 t/m ³)	l	730	730	730	580

*with Power boost

Note: 1. Bucket size based on SAE-J296, heaped material with a 1:1 angle of repose. 2. "Max permitted sizes" are for reference only and are not necessarily available from the factory.

Specifications

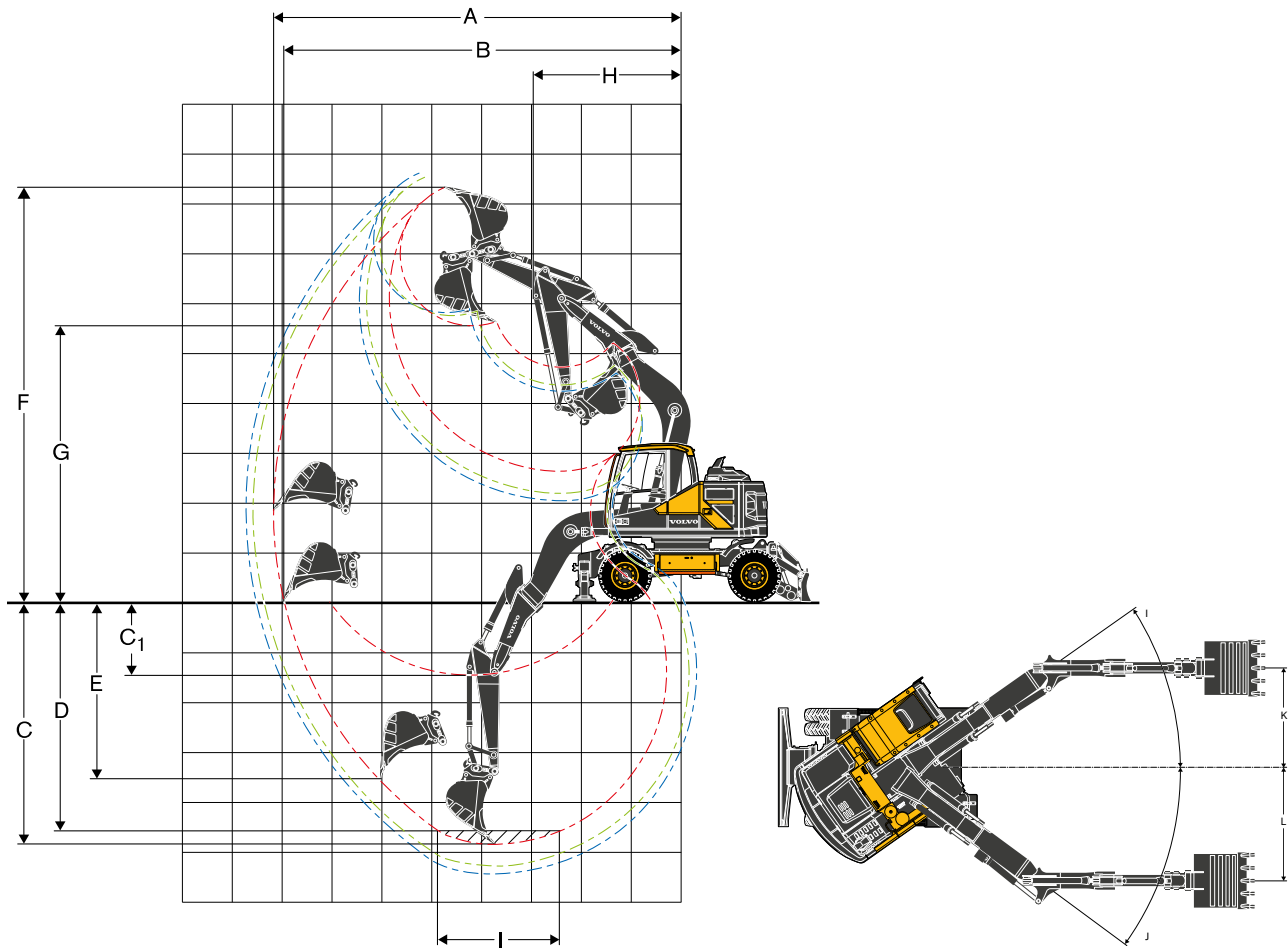

Mono offset boom 4.75 m and dipper arm 2.0 m, 2.45 m

WORKING RANGES & DIGGING FORCES

Description	Unit	Mono offset boom	
	m	4.75	
	m	2.0	2.45
A Max. digging reach	mm	8 170	8 580
B Max. digging reach on ground	mm	8 000	8 390
C Max. digging depth	mm	4 880	5 320
C ₁ Max. digging depth at max. attachment offset with vertical trench walls	mm	1 500	1 960
D Max. digging depth (l=2.44 m level)	mm	4 620	5 110
E Max. vertical wall digging depth	mm	3 570	4 010
F Max. cutting height	mm	8 280	8 480
G Max. dumping height	mm	5 500	5 710
H Min. front slew radius	mm	2 970	2 940
J	°	42	42
K	mm	2 420	2 420
L	mm	2 200	2 200
Digging forces with direct fit bucket			
Breakout force - bucket (ISO)	kN	108	108
Tearout force (ISO)	kN	73	63.5
Max. recommended sizes for direct fit buckets			
GP-Bucket (1.8 t/m ³)	l	870	780
HD-Bucket (2.1 t/m ³)	l	620	620
Max. recommended sizes for quick fit buckets			
S6/S60 QF GP-Bucket (1.8 t/m ³)	l	780	700
S6 QF HD-Bucket (2.1 t/m ³)	l	620	620
S1 QF GP-Bucket (1.8 t/m ³)	l	780	700
S1 QF HD-Bucket (2.1 t/m ³)	l	620	500

Note: 1. Bucket size based on SAE-J296, heaped material with a 1:1 angle of repose. 2. "Max permitted sizes" are for reference only and are not necessarily available from the factory.

LIFTING CAPACITY EWR150E - Welded undercarriage

At the arm end, without bucket and quick fit. For lifting capacity including bucket/quick fit, simply subtract actual weight of those parts from the following values. With heavy counterweight. Unit: 1 000kg

	Lifting point	Reach from machine centre (u = support up/d = support down)																					
		1.5 m				3.0 m				4.5 m				6.0 m				Max.					
		Across UC		Along UC		Across UC		Along UC		Across UC		Along UC		Across UC		Along UC		Across UC		Along UC		Max.	
		u	d	u	d	u	d	u	d	u	d	u	d	u	d	u	d	u	d	u	d	m	
4.5 m mono boom 2.0 m dipper arm Front radial blade Rear outriggers	7.5	-	-	-	-	-	-	-	-	-	-	-	-	-	-	-	-	-	-	-	-		
	6	-	-	-	-	-	-	-	-	3.8	4.1*	4.1*	4.1*	-	-	-	-	-	3.3	3.4*	3.4*	3.4*	4.9
	4.5	-	-	-	-	-	-	-	-	3.7	4.4*	4.4*	4.4*	-	-	-	-	-	2.4	3.2*	3.2*	3.2*	5.9
	3	-	-	-	-	6.3	8.0*	8.0*	8.0*	3.5	5.3*	5.3*	5.3*	2.3	4.0	3.7	4.3*	2.1	3.3*	3.3*	3.3*	6.4	
	1.5	-	-	-	-	-	-	-	-	3.3	6.0	5.6	6.2*	2.2	3.9	3.7	4.7*	2.0	3.4	3.2	3.6*	6.5	
	0	-	-	-	-	5.7	7.0*	7.0*	7.0*	3.2	5.8	5.5	6.6*	2.2	3.8	3.6	4.8*	2.1	3.6	3.4	4.2*	6.3	
	-1.5	-	-	-	-	5.8	9.3*	9.3*	9.3*	3.2	5.8	5.5	6.3*	-	-	-	-	-	2.4	4.2	4.0	4.8*	5.6
-3	-	-	-	-	5.9	7.0*	7.0*	7.0*	-	-	-	-	-	-	-	-	-	3.5	4.7*	4.7*	4.7*	5.3	
-4.5	-	-	-	-	-	-	-	-	-	-	-	-	-	-	-	-	-	2.7*	2.7*	2.7*	2.7*	4.5	
4.5 m mono boom 2.45 m dipper arm Front radial blade Rear outriggers	6	-	-	-	-	-	-	-	-	-	-	-	-	-	-	-	-	-	2.7*	2.7*	2.7*	2.7*	5.5
	4.5	-	-	-	-	-	-	-	-	3.8	3.9*	3.9*	3.9*	2.4	3.7*	3.7*	3.7*	2.2	2.6*	2.6*	2.6*	6.4	
	3	-	-	-	-	6.5	7.0*	7.0*	7.0*	3.6	4.9*	4.9*	4.9*	2.3	4.0	3.8	4.1*	1.9	2.6*	2.6*	2.6*	6.8	
	1.5	-	-	-	-	5.9	6.8*	6.8*	6.8*	3.4	5.9*	5.6	5.9*	2.2	3.9	3.7	4.5*	1.8	2.8*	2.8*	2.8*	6.9	
	0	-	-	-	-	5.7	7.2*	7.2*	7.2*	3.2	5.8	5.5	6.5*	2.2	3.8	3.6	4.8*	1.9	3.2*	3.1	3.2*	6.7	
	-1.5	5.8*	5.8*	5.8*	5.8*	5.7	9.7*	9.7*	9.7*	3.2	5.8	5.4	6.4*	2.2	3.8	3.6	4.5*	2.1	3.7	3.5	4.1*	6.1	
	-3	-	-	-	-	5.8	8.0*	8.0*	8.0*	3.2	5.3*	5.3*	5.3*	-	-	-	-	-	2.9	4.6*	4.6*	4.6*	4.9
-4.5	-	-	-	-	-	-	-	-	-	-	-	-	-	-	-	-	-	-	-	-	-	-	
4.5 m mono boom 2.6 m dipper arm Front radial blade Rear outriggers	6	-	-	-	-	-	-	-	-	-	-	-	-	-	-	-	-	-	2.5*	2.5*	2.5*	2.5*	5.6
	4.5	-	-	-	-	-	-	-	-	3.8*	3.8*	3.8*	3.8*	2.4	3.7*	3.7*	3.7*	2.1	2.4*	2.4*	2.4*	6.5	
	3	-	-	-	-	6.5	6.7*	6.6*	6.7*	3.6	4.7*	4.7*	4.7*	2.3	4.0	3.8	4.0*	1.8	2.4*	2.4*	2.4*	7.0	
	1.5	-	-	-	-	5.9	7.7*	7.8*	7.7*	3.3	5.8*	5.6	5.8*	2.2	3.9	3.6	4.4*	1.8	2.6*	2.6*	2.6*	7.1	
	0	-	-	-	-	5.7	7.3*	7.4*	7.3*	3.2	5.8	5.4	6.5*	2.1	3.8	3.6	4.8*	1.8	3.0*	2.9	3.0*	6.9	
	-1.5	5.6*	5.6*	5.6*	5.6*	5.6	9.9*	9.8*	9.9*	3.1	5.7	5.4	6.5*	2.1	3.8	3.5	4.6*	2.0	3.6	3.3	3.8*	6.2	
	-3	-	-	-	-	5.7	8.2*	8.2*	8.2*	3.2	5.5*	5.4	5.5*	-	-	-	-	-	2.7	4.5*	4.5*	4.5*	5.1
-4.5	-	-	-	-	-	-	-	-	-	-	-	-	-	-	-	-	-	-	-	-	-	-	
4.5 m mono boom 2.0 m dipper arm Radial Blade Rear	7.5	-	-	-	-	-	-	-	-	-	-	-	-	-	-	-	-	-	-	-	-	-	
	6	-	-	-	-	-	-	-	-	3.6	4.1	4.1*	4.1*	-	-	-	-	-	3.1	3.4*	3.4*	3.4*	4.9
	4.5	-	-	-	-	-	-	-	-	3.5	4.0	4.4*	4.4*	-	-	-	-	-	2.3	2.6	3.2*	3.2*	5.9
	3	-	-	-	-	6.0	7.0	8.0*	8.0*	3.3	3.8	5.3*	5.3*	2.2	2.5	3.6	4.3*	2.0	2.3	3.3	3.3*	6.4	
	1.5	-	-	-	-	-	-	-	-	3.1	3.6	5.4	6.2*	2.1	2.4	3.5	4.7*	1.9	2.1	3.1	3.1	3.6*	6.5
	0	-	-	-	-	5.4	6.4	7.0*	7.0*	3.0	3.5	5.3	6.6*	2.1	2.4	3.5	4.8*	1.9	2.2	3.3	4.2*	6.3	
	-1.5	-	-	-	-	5.4	6.4	9.3*	9.3*	3.0	3.5	5.3	6.3*	-	-	-	-	-	2.3	2.6	3.8	4.7*	5.6
-3	-	-	-	-	5.6	6.6	7.0*	7.0*	-	-	-	-	-	-	-	-	-	3.3	3.8	4.7*	4.7*	5.3	
-4.5	-	-	-	-	-	-	-	-	-	-	-	-	-	-	-	-	-	-	-	-	-	-	
4.5 m mono boom 2.45 m dipper arm Radial Blade Rear	6	-	-	-	-	-	-	-	-	-	-	-	-	-	-	-	-	-	2.7	2.7*	2.7*	2.7*	5.5
	4.5	-	-	-	-	-	-	-	-	3.6	3.9*	3.9*	3.9*	2.3	2.6	3.7*	3.7*	2.0	2.3	2.6*	2.6*	6.4	
	3	-	-	-	-	6.2	7.0*	7.0*	7.0*	3.4	3.9	4.9*	4.9*	2.2	2.5	3.6	4.1*	1.8	2.0	2.6*	2.6*	6.8	
	1.5	-	-	-	-	5.6	6.6	6.8*	6.8*	3.2	3.6	5.5	5.9*	2.1	2.4	3.5	4.5*	1.7	1.9	2.8*	2.8*	6.9	
	0	-	-	-	-	5.4	6.4	7.2*	7.2*	3.0	3.5	5.3	6.5*	2.0	2.3	3.5	4.8*	1.7	2.0	3.0	3.2*	6.7	
	-1.5	5.8*	5.8*	5.8*	5.8*	5.4	6.3	9.7*	9.7*	3.0	3.4	5.2	6.4*	2.0	2.3	3.4	4.5*	2.0	2.3	3.4	4.1*	6.1	
	-3	-	-	-	-	5.5	6.5	7.9*	7.9*	3.0	3.5	5.3*	5.3*	-	-	-	-	-	2.7	3.1	4.6*	4.6*	4.9
-4.5	-	-	-	-	-	-	-	-	-	-	-	-	-	-	-	-	-	-	-	-	-	-	
4.5 m mono boom 2.6 m dipper arm Radial Blade Rear	6	-	-	-	-	-	-	-	-	-	-	-	-	-	-	-	-	-	2.5*	2.5*	2.5*	2.5*	5.6
	4.5	-	-	-	-	-	-	-	-	3.6	3.8*	3.8*	3.8*	2.3	2.6	3.6*	3.6*	2.0	2.2	2.4*	2.4*	6.5	
	3	-	-	-	-	6.3	6.7*	6.7*	6.7*	3.4	3.9	4.7*	4.7*	2.2	2.5	3.7	4.0*	1.7	2.0	2.4*	2.4*	7.0	
	1.5	-	-	-	-	5.6	6.6	7.7*	7.7*	3.2	3.6	5.5	5.8*	2.1	2.4	3.5	4.4*	1.6	1.9	2.6*	2.6*	7.1	
	0	-	-	-	-	5.4	6.4	7.3*	7.3*	3.0	3.5	5.3	6.5*	2.0	2.3	3.5	4.7*	1.7	1.9	2.9	3.0*	6.9	
	-1.5	5.6*	5.6*	5.6*	5.6*	5.3	6.3	9.8*	9.8*	3.0	3.4	5.2	6.5*	2.0	2.3	3.4	4.6*	1.9	2.2	3.2	3.8*	6.2	
	-3	-	-	-	-	5.4	6.4	8.2*	8.2*	3.0	3.5	5.3	5.5*	-	-	-	-	-	2.5	2.9	4.4	4.5*	5.1
-4.5	-	-	-	-	-	-	-	-	-	-	-	-	-	-	-	-	-	-	-	-	-	-	

Notes: 1. Working pressure with Power Boost = 37.5 MPa. 2. The above values are in compliance with ISO standard 10 567. They do not exceed 87 % of hydraulic lifting capacity or 75 % of tipping load, with the machine on firm, level ground. 3. Load capacities marked with an asterisk (*) are limited by machine's hydraulic lifting capacity rather than tipping load.

Specifications

LIFTING CAPACITY EWR150E - Welded undercarriage

At the arm end, without bucket and quick fit. For lifting capacity including bucket/quick fit, simply subtract actual weight of those parts from the following values. With heavy counterweight. Unit: 1 000kg

	Lifting point	Reach from machine centre (u = support up/d = support down)																					
		1.5 m				3.0 m				4.5 m				6.0 m				Max.					
		Across UC		Along UC		Across UC		Along UC		Across UC		Along UC		Across UC		Along UC		Across UC		Along UC		Max.	
		u	d	u	d	u	d	u	d	u	d	u	d	u	d	u	d	u	d	u	d	m	
4.7 m 2 piece boom 2.0 m dipper arm Front radial blade Rear outriggers	7.5	-	-	-	-	-	-	-	-	-	-	-	-	-	-	-	-	-	4.4*	4.4*	4.4*	4.4*	3.5
	6	-	-	-	-	-	-	-	-	3.8	4.1*	4.1*	4.1*	-	-	-	-	-	2.9	3.5*	3.5*	3.5*	5.3
	4.5	-	-	-	-	5.6*	5.6*	5.6*	5.6*	3.7	4.5*	4.5*	4.5*	2.3	4.0	3.8	4.0*	2.2	3.2*	3.2*	3.2*	6.2	
	3	-	-	-	-	-	-	-	-	3.5	5.3*	5.3*	5.3*	2.3	3.9	3.7	4.3*	1.9	3.2*	3.1	3.2*	6.7	
	1.5	-	-	-	-	-	-	-	-	3.2	5.9	5.5	6.1*	2.2	3.8	3.6	4.6*	1.8	3.2	3.0	3.5*	6.8	
0	-	-	-	-	4.9*	4.9*	4.9*	4.9*	3.1	5.7	5.4	6.4*	2.1	3.7	3.5	4.7*	1.9	3.3	3.1	3.9*	6.5		
-1.5	-	-	-	-	5.5	8.6*	8.6*	8.6*	3.1	5.7	5.3	6.0*	-	-	-	-	-	2.1	3.8	3.6	4.2*	5.9	
4.7 m 2 piece boom 2.45 m dipper arm Front radial blade Rear outriggers	7.5	-	-	-	-	-	-	-	-	3.7*	3.7*	3.7*	3.7*	-	-	-	-	-	3.3*	3.3*	3.3*	3.3*	4.3
	6	-	-	-	-	-	-	-	-	3.7*	3.7*	3.7*	3.7*	-	-	-	-	-	2.5	2.7*	2.7*	2.7*	5.8
	4.5	-	-	-	-	-	-	-	-	3.8	4.1*	4.1*	4.1*	2.4	3.7*	3.7*	3.7*	2.0	2.6*	2.6*	2.6*	6.7	
	3	-	-	-	-	6.4	7.5*	7.5*	7.5*	3.5	5.0*	5.0*	5.0*	2.3	4.0	3.7	4.0*	1.7	2.6*	2.6*	2.6*	7.1	
	1.5	-	-	-	-	-	-	-	-	3.2	5.9*	5.6	5.9*	2.2	3.8	3.6	4.4*	1.6	2.7*	2.7*	2.7*	7.2	
0	-	-	-	-	5.4*	5.4*	5.4*	5.4*	3.1	5.7	5.4	6.4*	2.1	3.7	3.5	4.6*	1.7	3.0	2.8	3.1*	7.0		
-1.5	-	-	-	-	5.5	9.2*	9.2*	9.2*	3.0	5.7	5.3	6.2*	2.1	3.7	3.5	4.4*	1.9	3.4	3.2	3.7*	6.4		
4.7 m 2 piece boom 2.6 m dipper arm Front radial blade Rear outriggers	7.5	-	-	-	-	-	-	-	-	3.0*	3.0*	3.0*	3.0*	-	-	-	-	-	3.0*	3.0*	3.0*	3.0*	4.5
	6	-	-	-	-	-	-	-	-	3.5*	3.5*	3.5*	3.5*	-	-	-	-	-	2.4	2.5*	2.5*	2.5*	6.0
	4.5	-	-	-	-	-	-	-	-	3.8	3.9*	3.9*	3.9*	2.4	3.6*	3.6*	3.6*	1.9	2.4*	2.4*	2.4*	6.8	
	3	-	-	-	-	6.5	7.2*	7.2*	7.2*	3.5	4.9*	4.9*	4.9*	2.3	4.0	3.8	4.0*	1.7	2.4*	2.4*	2.4*	7.3	
	1.5	-	-	-	-	-	-	-	-	3.3	5.8*	5.6	5.8*	2.2	3.8	3.6	4.4*	1.6	2.5*	2.5*	2.5*	7.4	
0	-	-	-	-	5.4	5.4*	5.4*	5.4*	3.1	5.7	5.4	6.3*	2.1	3.7	3.5	4.6*	1.6	2.8*	2.7	2.8*	7.1		
-1.5	-	-	-	-	5.4	8.9*	8.9*	8.9*	3.0	5.6	5.3	6.2*	2.0	3.7	3.5	4.5*	1.8	3.3	3.1	3.4*	6.6		
4.7 m 2 piece boom 2.0 m dipper arm Radial Blade Rear	7.5	-	-	-	-	-	-	-	-	3.6	4.1*	4.1*	4.1*	-	-	-	-	-	4.4*	4.4*	4.4*	4.4*	3.5
	6	-	-	-	-	-	-	-	-	3.6	4.1*	4.1*	4.1*	-	-	-	-	-	2.8	3.2	3.5*	3.5*	5.3
	4.5	-	-	-	-	5.6*	5.6*	5.6*	5.6*	3.5	4.0	4.5*	4.5*	2.2	2.5	3.7	4.0*	2.1	2.4	3.2*	3.2*	6.2	
	3	-	-	-	-	-	-	-	-	3.3	3.8	5.3*	5.3*	2.1	2.5	3.6	4.3*	1.8	2.1	3.0	3.2*	6.7	
	1.5	-	-	-	-	-	-	-	-	3.0	3.5	5.4	6.1*	2.0	2.3	3.5	4.6*	1.7	2.0	2.9	3.5*	6.8	
0	-	-	-	-	4.9*	4.9*	4.9*	4.9*	2.9	3.4	5.2	6.4*	2.0	2.3	3.4	4.7*	1.7	2.0	3.0	3.9*	6.5		
-1.5	-	-	-	-	5.2	6.2	8.6*	8.6*	2.9	3.3	5.2	6.0*	-	-	-	-	-	2.0	2.3	3.5	4.2*	5.9	
4.7 m 2 piece boom 2.45 m dipper arm Radial Blade Rear	7.5	-	-	-	-	-	-	-	-	3.7*	3.7*	3.7*	3.7*	-	-	-	-	-	3.3*	3.3*	3.3*	3.3*	4.3
	6	-	-	-	-	-	-	-	-	3.7*	3.7*	3.7*	3.7*	-	-	-	-	-	2.4	2.7	2.7*	2.7*	5.8
	4.5	-	-	-	-	-	-	-	-	3.6	4.1*	4.1*	4.1*	2.3	2.6	3.7*	3.7*	1.9	2.1	2.6*	2.6*	6.7	
	3	-	-	-	-	6.1	7.1	7.5*	7.5*	3.3	3.8	5.0*	5.0*	2.2	2.5	3.6	4.0*	1.6	1.9	2.6*	2.6*	7.1	
	1.5	-	-	-	-	-	-	-	-	3.1	3.5	5.4	5.9*	2.0	2.4	3.5	4.4*	1.5	1.8	2.6	2.7*	7.2	
0	-	-	-	-	5.1	5.4*	5.4*	5.4*	2.9	3.4	5.2	6.4*	2.0	2.3	3.4	4.6*	1.6	1.8	2.7	3.1*	7.0		
-1.5	-	-	-	-	5.1	6.1	9.2*	9.2*	2.8	3.3	5.1	6.2*	1.9	2.2	3.4	4.4*	1.8	2.1	3.1	3.7*	6.4		
4.7 m 2 piece boom 2.6 m dipper arm Radial Blade Rear	7.5	-	-	-	-	-	-	-	-	3.1*	3.0*	3.1*	3.0*	-	-	-	-	-	3.1*	3.0*	3.1*	3.0*	4.5
	6	-	-	-	-	-	-	-	-	3.5*	3.5*	3.5*	3.5*	-	-	-	-	-	2.3	2.5*	2.6*	2.5*	6.0
	4.5	-	-	-	-	-	-	-	-	3.6	3.9*	3.9*	3.9*	2.3	2.6	3.6*	3.6*	1.8	2.1	2.4*	2.4*	6.8	
	3	-	-	-	-	6.1	7.2*	7.1*	7.2*	3.3	3.9	4.8*	4.9*	2.2	2.5	3.6	4.0*	1.6	1.8	2.4*	2.4*	7.3	
	1.5	-	-	-	-	-	-	-	-	3.0	3.6	5.4	5.8*	2.0	2.4	3.5	4.4*	1.5	1.7	2.5*	2.5*	7.4	
0	-	-	-	-	5.1	5.4*	5.5*	5.4*	2.9	3.4	5.2	6.3*	1.9	2.3	3.4	4.6*	1.5	1.8	2.6	2.8*	7.1		
-1.5	-	-	-	-	5.1	6.1	9.0*	8.9*	2.8	3.3	5.1	6.2*	1.9	2.2	3.3	4.5*	1.7	2.0	3.0	3.4*	6.6		

Notes: 1. Working pressure with Power Boost = 37.5 MPa. 2. The above values are in compliance with ISO standard 10 567. They do not exceed 87 % of hydraulic lifting capacity or 75 % of tipping load, with the machine on firm, level ground. 3. Load capacities marked with an asterisk (*) are limited by machine's hydraulic lifting capacity rather than tipping load.

LIFTING CAPACITY EWR150E - Welded undercarriage

At the arm end, without bucket and quick fit. For lifting capacity including bucket/quick fit, simply subtract actual weight of those parts from the following values. With heavy counterweight. Unit: 1 000kg

	Lifting point	Reach from machine centre (u = support up/d = support down)																				
		1.5 m				3.0 m				4.5 m				6.0 m				Max.				
		Across UC		Along UC		Across UC		Along UC		Across UC		Along UC		Across UC		Along UC		Across UC		Along UC		Max.
		m	u	d	u	d	u	d	u	d	u	d	u	d	u	d	u	d	u	d	u	d
4.75 m mono offset boom 2.0 m dipper arm Front radial blade Rear outriggers	6	-	-	-	-	-	-	-	-	3.8*	3.8*	3.8*	3.8*	-	-	-	-	3.0	3.3*	3.3*	3.3*	5.2
	4.5	-	-	-	-	-	-	-	-	3.7	4.1*	4.1*	4.1*	2.3	3.7*	3.7	3.7*	2.2	3.2*	3.2*	3.2*	6.1
	3	-	-	-	-	-	-	-	-	3.4	5*	5*	5*	2.2	3.8	3.6	4*	1.8	3.3	3.1	3.3*	6.6
	1.5	-	-	-	-	-	-	-	-	3.0	5.7	5.3	5.8*	2.0	3.7	3.5	4.3*	1.7	3.1	2.9	3.6*	6.7
	0	-	-	-	-	5.1	5.8*	5.8*	5.8*	2.9	5.5	5.1	6.2*	2.0	3.6	3.4	4.5*	1.8	3.2	3.0	4.1*	6.5
4.75 m mono offset boom 2.45 m dipper arm Front radial blade Rear outriggers	-1.5	5.5*	5.5*	5.5*	5.5*	5.1	6.2*	6.2*	6.2*	2.8	5.4	5.1	6*	1.9	3.5	3.3	4.3*	1.8	3.3	3.1	4*	6.3
	-3	-	-	-	-	5.4	6.8*	6.8*	6.8*	3.0	4.6*	4.6*	4.6*	-	-	-	-	2.9	4.4*	4.4*	4.4*	4.6
	6	-	-	-	-	-	-	-	-	3.7*	3.7*	3.7*	3.7*	2.3	3.4*	3.4*	3.4*	2.0	2.5*	2.5*	2.5*	6.6
	4.5	-	-	-	-	6.3	7*	7*	7*	3.4	4.6*	4.6*	4.6*	2.2	3.8*	3.7	3.8*	1.7	2.6*	2.6*	2.6*	7.0
	3	-	-	-	-	4.9*	4.9*	4.9*	4.9*	3.1	5.6*	5.4	5.6*	2.1	3.7	3.5	4.2*	1.6	2.8	2.7	2.8*	7.1
4.75 m mono offset boom 2.0 m dipper arm Radial Blade Rear	1.5	-	-	-	-	5.1	6.2*	6.2*	6.2*	2.9	5.5	5.2	6.1*	1.9	3.6	3.4	4.5*	1.6	2.9	2.8	3.3*	6.9
	0	-	-	-	-	4.7	5.7	6.2*	6.2*	2.7	3.2	5.0	6.1*	1.8	2.1	3.3	4.4*	1.6	1.9	2.9	4.1*	6.5
	-1.5	5.5*	5.5*	5.5*	5.5*	5.1	9.1*	9.1*	9.1*	2.8	5.4	5.1	6*	1.9	3.5	3.3	4.3*	1.8	3.3	3.1	4*	6.3
	-3	-	-	-	-	5.2	7.6*	7.6*	7.6*	2.9	5.1*	5.1*	5.1*	-	-	-	-	2.4	4.2*	4.2	4.2*	5.2
	6	-	-	-	-	-	-	-	-	3.6	3.8*	3.8*	3.8*	-	-	-	-	2.8	3.2	3.3*	3.3*	5.2
4.75 m mono offset boom 2.0 m dipper arm Radial Blade Rear	4.5	-	-	-	-	-	-	-	-	3.5	4.0	4.1*	4.1*	2.1	2.5	3.6	3.7*	2.0	2.4	3.2*	3.2*	6.1
	3	-	-	-	-	-	-	-	-	3.2	3.7	5*	5*	2.0	2.4	3.5	4*	1.7	2.0	3.0	3.3*	6.6
	1.5	-	-	-	-	-	-	-	-	2.8	3.3	5.2	5.8*	1.9	2.2	3.4	4.3*	1.6	1.9	2.8	3.6*	6.7
	0	-	-	-	-	4.8	5.7	5.8*	5.8*	2.7	3.2	5.0	6.2*	1.8	2.1	3.3	4.5*	1.6	1.9	2.9	4.1*	6.5
	-1.5	5.5*	5.5*	5.5*	5.5*	4.8	5.8	8.6*	8.6*	2.6	3.1	4.9	5.9*	-	-	-	-	1.9	2.2	3.4	4.3*	5.8
4.75 m mono offset boom 2.45 m dipper arm Radial Blade Rear	-3	-	-	-	-	5.0	6.0	6.8*	6.8*	2.8	3.2	4.6*	4.6*	-	-	-	-	2.7	3.2	4.4*	4.4*	4.6
	6	-	-	-	-	-	-	-	-	3.6	3.7*	3.7*	3.7*	2.2	2.5	3.4*	3.4*	1.8	2.1	2.5*	2.5*	6.6
	4.5	-	-	-	-	5.9	7.0	7*	7*	3.2	3.7	4.6*	4.6*	2.1	2.4	3.6	3.8*	1.6	1.8	2.6*	2.6*	7.0
	3	-	-	-	-	4.9*	4.9*	4.9*	4.9*	2.9	3.4	5.2	5.6*	1.9	2.2	3.4	4.2*	1.5	1.7	2.6	2.8*	7.1
	1.5	-	-	-	-	4.7	5.7	6.2*	6.2*	2.7	3.2	5.0	6.1*	1.8	2.1	3.3	4.4*	1.5	1.7	2.7	3.3*	6.9
4.75 m mono offset boom 2.0 m dipper arm Radial Blade Rear	0	-	-	-	-	4.7	5.7	6.2*	6.2*	2.7	3.2	5.0	6.1*	1.8	2.1	3.3	4.4*	1.5	1.7	2.7	3.3*	6.9
	-1.5	5.5*	5.5*	5.5*	5.5*	4.7	5.7	9*	9*	2.6	3.1	4.9	6*	1.8	2.1	3.2	4.3*	1.7	1.9	3.0	4*	6.3
	-3	-	-	-	-	4.9	5.9	7.5*	7.5*	2.7	3.2	5.0	5.1*	-	-	-	-	2.2	2.6	4.0	4.2*	5.2

Notes: 1. Working pressure with Power Boost = 37.5 MPa. 2. The above values are in compliance with ISO standard 10 567. They do not exceed 87 % of hydraulic lifting capacity or 75 % of tipping load, with the machine on firm, level ground. 3. Load capacities marked with an asterisk (*) are limited by machine's hydraulic lifting capacity rather than tipping load.

LIFTING CAPACITY EWR150E - Bolted undercarriage

At the arm end, without bucket and quick fit. For lifting capacity including bucket/quick fit, simply subtract actual weight of those parts from the following values. With heavy counterweight. Unit: 1 000kg

	Lifting point	Reach from machine centre (u = support up/d = support down)																				
		1.5 m				3.0 m				4.5 m				6.0 m				Max.				
		Across UC		Along UC		Across UC		Along UC		Across UC		Along UC		Across UC		Along UC		Across UC		Along UC		Max.
		m	u	d	u	d	u	d	u	d	u	d	u	d	u	d	u	d	u	d	u	d
4.75 m mono offset boom 2.0 m dipper arm Front Parallel blade Rear outriggers	6	-	-	-	-	-	-	-	-	3.8*	3.8*	3.8*	3.8*	-	-	-	-	3.2	3.3*	3.3*	3.3*	5.2
	4.5	-	-	-	-	-	-	-	-	3.9	4.1*	4.1*	4.1*	2.4	3.7*	3.7*	3.7*	2.3	3.2*	3.2*	3.2*	6.1
	3	-	-	-	-	-	-	-	-	3.6	5.0*	5.0*	5.0*	2.3	4.0*	3.8	4.0*	2.0	3.3*	3.2	3.3*	6.6
	1.5	-	-	-	-	-	-	-	-	3.3	5.8*	5.6	5.8*	2.2	4.0	3.6	4.3*	1.9	3.3	3.1	3.6*	6.7
	0	-	-	-	-	5.5	5.8*	5.8*	5.8*	3.1	5.9	5.4	6.2*	2.1	3.9	3.5	4.5*	1.9	3.5	3.2	4.1*	6.5
4.75 m mono offset boom 2.45 m dipper arm Front Parallel blade Rear outriggers	-1.5	5.5*	5.5*	5.5*	5.5*	5.5	6.2*	6.2*	6.2*	3.1	5.9	5.4	6.1*	2.1	3.9	3.5	4.4*	1.9	3.2	2.9	3.3*	6.9
	-3	-	-	-	-	5.8	6.8*	6.8*	6.8*	3.2	4.6*	4.6*	4.6*	-	-	-	-	3.1	4.4*	4.4*	4.4*	4.6
	6	-	-	-	-	-	-	-	-	3.7	3.8*	3.8*	3.8*	-	-	-	-	2.6*	2.6*	2.6*	2.6*	5.7
	4.5	-	-	-	-	6.7	7.0*	7.0*	7.0*	3.7	4.6*	4.6*	4.6*	2.4	3.8*	3.8*	3.8*	1.8	2.6*	2.6*	2.6*	7.0
	3	-	-	-	-	4.9*	4.9*	4.9*	4.9*	3.3	5.6*	5.6*	5.6*	2.2	4.0	3.7	4.2*	1.7	2.8*	2.8	2.8*	7.1
4.75 m mono offset boom 2.0 m dipper arm Parallel Blade Rear	1.5	-	-	-	-	5.5	6.2*	6.2*	6.2*	3.1	5.9	5.4	6.1*	2.1	3.9	3.5	4.4*	1.7	3.2	2.9	3.3*	6.9
	0	-	-	-	-	5.5	9.0*	9.0*	9.0*	3.0	5.8	5.3	6.0*	2.1	3.8	3.5	4.3*	1.9	3.6	3.3	4.0*	6.3
	-1.5	5.5*	5.5*	5.5*	5.5*	5.5	9.0*	9.0*	9.0*	3.0	5.8	5.3	6.0*	2.1	3.8	3.5	4.3*	1.9	3.6	3.3	4.0*	6.3
	-3	-	-	-	-	5.6	7.5*	7.5*	7.5*	3.1	5.1*	5.1*	5.1*	-	-	-	-	2.6	4.2*	4.2*	4.2*	5.2
	6	-	-	-	-	-	-	-	-	3.7	3.8*	3.8*	3.8*	-	-	-	-	2.9	3.3	3.3*	3.3*	5.2
4.75 m mono offset boom 2.0 m dipper arm Parallel Blade Rear	4.5	-	-	-	-	-	-	-	-	3.6	4.1	4.1*	4.1*	2.2	2.5	3.7*	3.7*	2.1	2.4	3.2*	3.2*	6.1
	3	-	-	-	-	-	-	-	-	3.3	3.8	5.0*	5.0*	2.1	2.4	3.7*	4.0*	1.8	2.1	3.1	3.3*	6.6
	1.5	-	-	-	-	-	-	-	-	3.0	3.5	5.4	5.8*	2.0	2.3	3.5	4.3*	1.7	1.9	3.0	3.6*	6.7
	0	-	-	-	-	5.0	5.8*	5.8*	5.8*	2.8	3.3	5.2	6.2*	1.9	2.2	3.4	4.5*	1.7	2.0	3.1	4.1*	6.5
	-1.5	5.5*	5.5*	5.5*	5.5*	5.0	6.0	8.6*	8.6*	2.8	3.2	5.2	5.9*	-	-	-	-	2.0	2.3	3.5	4.3*	5.8
4.75 m mono offset boom 2.45 m dipper arm Parallel Blade Rear	-3	-	-	-	-	5.2	6.2	6.8*	6.8*	2.9	3.4	4.6*	4.6*	-	-	-	-	2.8	3.3	4.4*	4.4*	4.6
	6	-	-	-	-	-	-	-	-	3.7	3.0	3.7*	3.7*	2.3	1.8	3.4*	3.4*	1.9	1.5	2.5*	2.5*	6.6
	4.5	-	-	-	-	6.1	5.1	7.0*	7.0*	3.4	2.7	4.6*	4.6*	2.1	1.6	3.7	3.8*	1.6	1.2	2.6*	2.6*	7.0
	3	-	-	-	-	4.9*	4.1	4.9*	4.9*	3.0	2.3	5.5	5.6*	2.0	1.5	3.5	3.9	1.5	1.1	2.7	2.8*	7.1
	1.5	-	-	-	-	4.9	3.8	6.2*	6.2*	2.8	2.1	5.2	6.1*	1.9	1.4	3.4	3.7	1.5	1.1	2.8	3.0	6.9
4.75 m mono offset boom 2.0 m dipper arm Parallel Blade Rear	0	-	-	-	-	4.9	3.8	6.2*	6.2*	2.8	2.1	5.2	6.1*	1.9	1.4	3.4	3.7	1.5	1.1	2.8	3.0	6.9
	-1.5	5.5*	5.5*	5.5*	5.5*	4.9	3.8	9.0*	9.0*	2.7	2.0	5.1	6.0*	1.8	1.3	3.4	3.7	1.7	1.2	3.1	3.4	6.3
	-3	-	-	-	-	5.1	4.0	7.5*	7.5*	2.8	2.1	5.1*	5.1*	-	-	-	-	2.3	1.7	4.2	4.2*	5.2

Notes: 1. Working pressure with Power Boost = 37.5 MPa. 2. The above values are in compliance with ISO standard 10 567. They do not exceed 87 % of hydraulic lifting capacity or 75 % of tipping load, with the machine on firm, level ground. 3. Load capacities marked with an asterisk (*) are limited by machine's hydraulic lifting capacity rather than tipping load.

Specifications

LIFTING CAPACITY EWR150E - Bolted undercarriage

At the arm end, without bucket and quick fit. For lifting capacity including bucket/quick fit, simply subtract actual weight of those parts from the following values. With heavy counterweight. Unit: 1 000kg

	Lifting point	Reach from machine centre (u = support up/d = support down)																					
		1.5 m				3.0 m				4.5 m				6.0 m				Max.					
		Across UC		Along UC		Across UC		Along UC		Across UC		Along UC		Across UC		Along UC		Across UC		Along UC		Max.	
		u	d	u	d	u	d	u	d	u	d	u	d	u	d	u	d	u	d	u	d	m	
4.5 m mono boom	6	-	-	-	-	-	-	-	-	4.0	4.1*	4.1*	4.1*	-	-	-	-	3.4*	3.4*	3.4*	3.4*	4.9	
	4.5	-	-	-	-	-	-	-	-	4.0	4.4*	4.4*	4.4*	-	-	-	-	2.6	3.2*	3.2*	3.2*	5.9	
	3	-	-	-	-	6.8	8.0*	8.0*	8.0*	3.8	5.3*	5.3*	5.3*	2.5	4.2	3.9	4.3*	2.2	3.3*	3.3*	3.3*	6.4	
	1.5	-	-	-	-	-	-	-	-	3.6	6.2*	5.9	6.2*	2.4	4.1	3.8	4.7*	2.1	3.6*	3.4	3.6*	6.5	
	0	-	-	-	-	6.1	7.0*	7.0*	7.0*	3.5	6.2	5.7	6.6*	2.4	4.1	3.8	4.8*	2.2	3.8	3.5	4.2*	6.3	
Front Parallel blade	-1.5	-	-	-	-	6.2	9.3*	9.3*	9.3*	3.4	6.2	5.7	6.3*	-	-	-	-	2.6	4.5	4.2	4.7*	5.6	
Rear outriggers	-3	-	-	-	-	6.3	7.0*	7.0*	7.0*	-	-	-	-	-	-	-	-	3.8	4.7*	4.7*	4.7*	4.3	
4.5 m mono boom	6	-	-	-	-	-	-	-	-	3.9*	3.9*	3.9*	3.9*	2.6	2.8	3.7*	3.7*	2.3	2.7*	2.7*	2.7*	5.5	
	4.5	-	-	-	-	-	-	-	-	3.9*	3.9*	3.9*	3.9*	2.6	2.8	3.7*	3.7*	2.3	2.5	2.6*	2.6*	6.4	
	3	-	-	-	-	7.0	7.0*	7.0*	7.0*	3.8	4.4	4.9*	4.9*	2.5	2.8	3.9	4.1*	2.0	2.2	2.6*	2.6*	6.8	
	1.5	-	-	-	-	6.3	6.8*	6.8*	6.8*	3.6	4.2	5.9	5.9*	2.4	2.7	3.8	4.5*	2.0	2.1	2.8*	2.8*	6.9	
	0	-	-	-	-	6.1	7.2*	7.2*	7.2*	3.4	4.0	5.7	6.5*	2.3	2.6	3.7	4.8*	2.0	2.2	3.2	3.2*	6.7	
Front Parallel blade	-1.5	5.8*	5.8*	5.8*	5.8*	6.1	8.2	9.7*	9.7*	3.4	3.9	5.7	6.4*	2.3	2.6	3.7	4.5*	2.3	2.5	3.7	4.1*	6.1	
Rear outriggers	-3	-	-	-	-	6.2	7.9*	7.9*	7.9*	3.5	4.0	5.3*	5.3*	-	-	-	-	3.1	3.5	4.6*	4.6*	4.9	
	-4.5	-	-	-	-	-	-	-	-	-	-	-	-	-	-	-	-	-	-	-	-	-	
4.5 m mono boom	6	-	-	-	-	-	-	-	-	-	-	-	-	-	-	-	-	2.5*	2.5*	2.5*	2.5*	5.6	
	4.5	-	-	-	-	-	-	-	-	3.8*	3.8*	3.8*	3.8*	2.6	3.6*	3.6*	3.6*	2.2	2.4*	2.4*	2.4*	6.5	
	3	-	-	-	-	6.7*	6.7*	6.7*	6.7*	3.8	4.7*	4.7*	4.7*	2.5	4.0*	3.9	4.0*	2.0	2.4*	2.4*	2.4*	7.0	
	1.5	-	-	-	-	6.4	7.7*	7.7*	7.7*	3.6	5.8*	5.8*	5.8*	2.4	4.1	3.8	4.4*	1.9	2.6*	2.6*	2.6*	7.1	
	0	-	-	-	-	6.1	7.3*	7.3*	7.3*	3.4	6.2	5.7	6.5*	2.3	4.1	3.7	4.7*	1.9	3.0*	3.0*	3.0*	6.9	
Front Parallel blade	-1.5	5.6*	5.6*	5.6*	5.6*	6.1	9.8*	9.8*	9.8*	3.4	6.2	5.7	6.5*	2.3	4.0	3.7	4.6*	2.2	3.8*	3.5	3.8*	6.2	
Rear outriggers	-3	-	-	-	-	6.2	8.2*	8.2*	8.2*	3.4	5.5*	5.5*	5.5*	-	-	-	-	2.9	4.5*	4.5*	4.5*	5.1	
4.5 m mono boom	6	-	-	-	-	-	-	-	-	3.7	4.1*	4.1*	4.1*	-	-	-	-	3.2	3.4*	3.4*	3.4*	4.9	
	4.5	-	-	-	-	-	-	-	-	3.7	4.2	4.4*	4.4*	-	-	-	-	2.4	2.7	3.2*	3.2*	5.9	
	3	-	-	-	-	6.2	7.3	8.0*	8.0*	3.5	4.0	5.3*	5.3*	2.3	2.6	3.8	4.3*	2.0	2.3	3.3*	3.3*	6.4	
	1.5	-	-	-	-	-	-	-	-	3.2	3.7	5.7	6.2*	2.2	2.5	3.7	4.7*	1.9	2.2	3.3	3.6*	6.5	
	0	-	-	-	-	5.6	6.6	7.0*	7.0*	3.1	3.6	5.5	6.6*	2.1	2.5	3.6	4.8*	2.0	2.3	3.4	4.2*	6.3	
Parallel Blade Rear	-1.5	-	-	-	-	5.6	6.6	9.3*	9.3*	3.1	3.6	5.5	6.3*	-	-	-	-	2.3	2.7	4.0	4.7*	5.6	
Rear outriggers	-3	-	-	-	-	5.8	6.8	7.0*	7.0*	-	-	-	-	-	-	-	-	3.4	4.0	4.7*	4.7*	4.3	
4.5 m mono boom	6	-	-	-	-	-	-	-	-	-	-	-	-	-	-	-	-	2.7*	2.2	2.7*	2.7*	5.5	
	4.5	-	-	-	-	-	-	-	-	3.7	3.0	3.9*	3.9*	2.4	1.8	3.7*	3.7*	2.1	1.6	2.6*	2.6*	6.4	
	3	-	-	-	-	6.4	5.3	7.0*	7.0*	3.5	2.8	4.9*	4.9*	2.3	1.8	3.8	4.1*	1.9	1.4	2.6*	2.6*	6.8	
	1.5	-	-	-	-	5.8	4.7	6.8*	6.8*	3.3	2.6	5.7	5.9*	2.2	1.7	3.7	4.0	1.8	1.3	2.8*	2.8*	6.9	
	0	-	-	-	-	5.6	4.4	7.2*	7.2*	3.1	2.4	5.5	6.5	2.1	1.6	3.6	3.9	1.8	1.4	3.1	3.2*	6.7	
Parallel Blade Rear	-1.5	5.8*	5.8*	5.8*	5.8*	5.6	4.4	9.7*	9.7*	3.1	2.4	5.5	6.4	2.1	1.6	3.6	3.9	2.1	1.6	3.5	3.8	6.1	
Rear outriggers	-3	-	-	-	-	5.7	4.6	7.9*	7.9*	3.1	2.4	5.3*	5.3*	-	-	-	-	2.8	2.2	4.6*	4.6*	4.9	
4.5 m mono boom	6	-	-	-	-	-	-	-	-	-	-	-	-	-	-	-	-	2.5*	2.5*	2.5*	2.5*	5.6	
	4.5	-	-	-	-	-	-	-	-	3.7	3.8*	3.8*	3.8*	2.4	2.7	3.6*	3.6*	2.0	2.3	2.4*	2.4*	6.5	
	3	-	-	-	-	6.5	6.7*	6.7*	6.7*	3.5	4.0	4.7*	4.7*	2.3	2.6	3.8	4.0*	1.8	2.1	2.4*	2.4*	7.0	
	1.5	-	-	-	-	5.8	6.9	7.7*	7.7*	3.3	3.8	5.7	5.8*	2.2	2.5	3.7	4.4*	1.7	2.0	2.6*	2.6*	7.1	
	0	-	-	-	-	5.6	6.6	7.3*	7.3*	3.1	3.6	5.5	6.5*	2.1	2.4	3.6	4.7*	1.8	2.0	3.0	3.0*	6.9	
Parallel Blade Rear	-1.5	5.6*	5.6*	5.6*	5.6*	5.5	6.6	9.8*	9.8*	3.1	3.6	5.5	6.5*	2.1	2.4	3.6	4.6*	2.0	2.3	3.4	3.8*	6.2	
Rear outriggers	-3	-	-	-	-	5.6	6.7	8.2*	8.2*	3.1	3.6	5.5*	5.5*	-	-	-	-	2.6	3.0	4.5*	4.5*	5.1	

Notes: 1. Working pressure with Power Boost = 37.5 MPa. 2. The above values are in compliance with ISO standard 10 567. They do not exceed 87 % of hydraulic lifting capacity or 75 % of tipping load, with the machine on firm, level ground. 3. Load capacities marked with an asterisk (*) are limited by machine's hydraulic lifting capacity rather than tipping load.

LIFTING CAPACITY EWR150E - Bolted undercarriage

At the arm end, without bucket and quick fit. For lifting capacity including bucket/quick fit, simply subtract actual weight of those parts from the following values. With heavy counterweight. Unit: 1 000kg

	Lifting point	Reach from machine centre (u = support up/d = support down)																					
		1.5 m				3.0 m				4.5 m				6.0 m				Max.					
		Across UC		Along UC		Across UC		Along UC		Across UC		Along UC		Across UC		Along UC		Across UC		Along UC		Max.	
		m	u	d	u	d	u	d	u	d	u	d	u	d	u	d	u	d	u	d	u	d	m
4.7 m 2 piece boom 2.0 m dipper arm Front parallel blade Rear outriggers	7.5	-	-	-	-	-	-	-	-	-	-	-	-	-	-	-	-	-	4.4*	4.4*	4.4*	4.4*	3.5
	6	-	-	-	-	-	-	-	-	4.1	4.1*	4.1*	4.1*	-	-	-	-	-	3.1	3.5*	3.5*	3.5*	5.3
	4.5	-	-	-	-	5.6*	5.6*	5.6*	5.6*	4.0	4.5*	4.5*	4.5*	2.5	4.0*	4.0	4.0*	2.4	3.2*	3.2*	3.2*	6.2	
	3	-	-	-	-	-	-	-	-	3.7	5.3*	5.3*	5.3*	2.4	4.2	3.9	4.3*	2.1	3.2*	3.2*	3.2*	6.7	
	1.5	-	-	-	-	-	-	-	-	3.5	6.1*	5.8	6.1*	2.3	4.1	3.8	4.6*	2.0	3.4	3.1	3.5*	6.8	
	0	-	-	-	-	4.9*	4.9*	4.9*	4.9*	3.3	6.1	5.6	6.4*	2.3	4.0	3.7	4.7*	2.0	3.6	3.3	3.9*	6.5	
-1.5	-	-	-	-	5.9	8.6*	8.6*	8.6*	3.3	6.0*	5.6	6.0*	-	-	-	-	-	2.3	4.1	3.8	4.2*	5.9	
4.7 m 2 piece boom 2.45 m dipper arm Front parallel blade Rear outriggers	7.5	-	-	-	-	-	-	-	-	3.7*	3.7*	3.7*	3.7*	-	-	-	-	-	3.3*	3.3*	3.3*	3.3*	4.3
	6	-	-	-	-	-	-	-	-	3.7*	3.7*	3.7*	3.7*	-	-	-	-	-	2.7	2.7*	2.7*	2.7*	5.8
	4.5	-	-	-	-	-	-	-	-	4.0	4.1*	4.1*	4.1*	2.6	3.7*	3.7*	3.7*	2.1	2.6*	2.6*	2.6*	6.7	
	3	-	-	-	-	6.8	7.5*	7.5*	7.5*	3.8	5.0*	5.0*	5.0*	2.5	4.0*	3.9	4.0*	1.9	2.6*	2.6*	2.6*	7.1	
	1.5	-	-	-	-	-	-	-	-	3.5	5.9*	5.8	5.9*	2.3	4.1	3.8	4.4*	1.8	2.7*	2.7*	2.7*	7.2	
	0	-	-	-	-	5.4*	5.4*	5.4*	5.4*	3.3	6.1	5.6	6.4*	2.3	4.0	3.7	4.6*	1.8	3.1*	3.0	3.1*	7.0	
-1.5	-	-	-	-	5.9	9.2*	9.2*	9.2*	3.3	6.1	5.6	6.2*	2.2	4.0	3.7	4.4*	2.1	3.6	3.4	3.7*	6.4		
4.7 m 2 piece boom 2.6 m dipper arm Front parallel blade Rear outriggers	7.5	-	-	-	-	-	-	-	-	3.0*	3.0*	3.0*	3.0*	-	-	-	-	-	3.0*	3.0*	3.0*	3.0*	4.5
	6	-	-	-	-	-	-	-	-	3.5*	3.5*	3.5*	3.5*	-	-	-	-	-	2.5*	2.5*	2.5*	2.5*	6.0
	4.5	-	-	-	-	-	-	-	-	3.9*	3.9*	3.9*	3.9*	2.6	3.6*	3.6*	3.6*	2.0	2.4*	2.4*	2.4*	6.8	
	3	-	-	-	-	6.9	7.2*	7.2*	7.2*	3.8	4.9*	4.9*	4.9*	2.5	4.0*	3.9	4.0*	1.8	2.4*	2.4*	2.4*	7.3	
	1.5	-	-	-	-	-	-	-	-	3.5	5.8*	5.8*	5.8*	2.3	4.1	3.8	4.4*	1.7	2.5*	2.5*	2.5*	7.4	
	0	-	-	-	-	5.4*	5.4*	5.4*	5.4*	3.3	6.1	5.6	6.3*	2.2	4.0	3.7	4.6*	1.8	2.8*	2.8*	2.8*	7.1	
-1.5	-	-	-	-	5.9	8.9*	8.9*	8.9*	3.2	6.1	5.5	6.2*	2.2	4.0	3.6	4.5*	2.0	3.4*	3.2	3.4*	6.6		
4.7 m 2 piece boom 2.0 m dipper arm Parallel Blade Rear	7.5	-	-	-	-	-	-	-	-	3.8	4.1*	4.1*	4.1*	-	-	-	-	-	4.4*	4.4*	4.4*	4.4*	3.5
	6	-	-	-	-	-	-	-	-	3.8	4.1*	4.1*	4.1*	-	-	-	-	-	2.9	3.3	3.5*	3.5*	5.3
	4.5	-	-	-	-	5.6*	5.6*	5.6*	5.6*	3.6	4.2	4.5*	4.5*	2.3	2.6	3.8	4.0*	2.2	2.5	3.2*	3.2*	6.2	
	3	-	-	-	-	-	-	-	-	3.4	3.9	5.3*	5.3*	2.2	2.5	3.8	4.3*	1.9	2.1	3.2	3.2*	6.7	
	1.5	-	-	-	-	-	-	-	-	3.1	3.6	5.6	6.1*	2.1	2.4	3.6	4.6*	1.8	2.0	3.0	3.5*	6.8	
	0	-	-	-	-	4.9*	4.9*	4.9*	4.9*	3.0	3.5	5.4	6.4*	2.0	2.4	3.6	4.7*	1.8	2.1	3.2	3.9*	6.5	
-1.5	-	-	-	-	5.4	6.4	8.6*	8.6*	3.0	3.5	5.4	6.0*	-	-	-	-	-	2.1	2.4	3.7	4.2*	5.9	
4.7 m 2 piece boom 2.45 m dipper arm Parallel Blade Rear	7.5	-	-	-	-	-	-	-	-	3.1*	3.0*	3.1*	3.0*	-	-	-	-	-	3.3*	3.3*	3.3*	3.3*	4.3
	6	-	-	-	-	-	-	-	-	3.7*	3.2	3.7*	3.7*	-	-	-	-	-	2.5	1.9	2.7*	2.7*	5.8
	4.5	-	-	-	-	-	-	-	-	3.7	3.0	4.1*	4.1*	2.3	1.8	3.7*	3.7*	1.9	1.5	2.6*	2.6*	6.7	
	3	-	-	-	-	6.3	5.2	7.5*	7.5*	3.4	2.8	5.0*	5.0*	2.2	1.7	3.8	4.0*	1.7	1.3	2.6*	2.6*	7.1	
	1.5	-	-	-	-	-	-	-	-	3.2	2.5	5.6	5.9*	2.1	1.6	3.7	4.0	1.6	1.2	2.7*	2.7*	7.2	
	0	-	-	-	-	5.3	4.2	5.4*	5.4*	3.0	2.3	5.4	6.4*	2.0	1.5	3.6	3.9	1.6	1.2	2.9	3.0	7.0	
-1.5	-	-	-	-	5.3	4.2	9.2*	9.2*	2.9	2.2	5.4	6.2*	2.0	1.5	3.5	3.9	1.8	1.4	3.2	3.5	6.4		
4.7 m 2 piece boom 2.6 m dipper arm Parallel Blade Rear	7.5	-	-	-	-	-	-	-	-	3.5*	3.5*	3.5*	3.5*	-	-	-	-	-	2.4	2.5*	2.6*	2.5*	6.0
	6	-	-	-	-	-	-	-	-	3.7	3.9*	3.9*	3.9*	2.3	2.7	3.6*	3.6*	1.9	2.1	2.4*	2.4*	6.8	
	4.5	-	-	-	-	-	-	-	-	3.7	3.9*	3.9*	3.9*	2.3	2.7	3.6*	3.6*	1.9	2.1	2.4*	2.4*	6.8	
	3	-	-	-	-	6.3	7.2*	7.1*	7.2*	3.4	4.0	4.8*	4.9*	2.2	2.6	3.8	4.0*	1.6	1.9	2.4*	2.4*	7.3	
	1.5	-	-	-	-	-	-	-	-	3.2	3.7	5.6	5.8*	2.1	2.4	3.6	4.4*	1.5	1.8	2.5*	2.5*	7.4	
	0	-	-	-	-	5.3	5.4*	5.5*	5.4*	3.0	3.5	5.4	6.3*	2.0	2.3	3.5	4.6*	1.6	1.8	2.8	2.8*	7.1	
-1.5	-	-	-	-	5.3	6.3	9.0*	8.9*	2.9	3.4	5.3	6.2*	2.0	2.3	3.5	4.5*	1.8	2.1	3.1	3.4*	6.6		

Notes: 1. Working pressure with Power Boost = 37.5 MPa. 2. The above values are in compliance with ISO standard 10 567. They do not exceed 87 % of hydraulic lifting capacity or 75 % of tipping load, with the machine on firm, level ground. 3. Load capacities marked with an asterisk (*) are limited by machine's hydraulic lifting capacity rather than tipping load.

Equipment

STANDARD EQUIPMENT

Engine

Turbocharged, 4 stroke Volvo diesel engine with water cooling, direct injection and charged air cooler that meets EU Stage IV emission requirements

Intake air pre-heater

ECO- Modus

Fuel filter and water separator

Fuel filler pump: 50 l/min with automatic shut-off

Aluminium core radiator

Electric/Electronic control system

Contronics-computerized monitoring and diagnostic system

Master electrical disconnect switch

Adjustable automatic idling system

One-touch power boost

Adjustable monitor

Safety stop/start function

2 Frame mounted halogen lamps

Alternator, 120 A

Batteries, 2 x 12 V/140 Ah

Start motor, 24 V/5.5 kW

CareTrack via GSM or satellite

Rear view camera

Undercarriage

3 speeds (creep / offroad / road speed up to 35 km/h)

Oscillating front axle $\pm 9^\circ$ with out mudguards/ 6° with mudguards

2-circuit travel brakes

Maintenance-free propeller shafts

Superstructure

LED Rear lights

Service walkway with anti-slip grating

Centralised lubricating point for slew bearing and boom

Digging equipment

Attachment points for extra hydraulics

Centralised lubrication point for arm and bucket

Cab and interior

Volvo Care Cab with fixed roof hatch /ROPS

Cup holder

Door locks

Safety glass, light tinted

Floor mat

Horn

Large storage area

Pull-up type front window

Removable lower windshield

Retractable seat belt

Windshield wiper with washer and intermittent feature

Sun shield, front, roof & rear

Bluetooth radio with USB port

Master ignition key

Multi function switch on LH Joystick

Heater & air-conditioner, automatic

Hydraulic dampening cab mounts

Adjustable operator seat and joystick control console

Adjustable steering column

Hydraulic safety lock lever

Control joystick, with 5 switches each

Hydraulic system

Load sensing hydraulic system

Cylinder cushioning

Cylinder contamination seals

Return filter of full flow type 2 000 h exchange interval

Pressure relief system (servo accumulator)

Proportional controlled visco-clutch cooling fan

Hose rupture valve for boom and arm

Hydraulic long life oil ISO VG 46

OPTIONAL EQUIPMENT

Engine

Diesel coolant heater with digital timer

Block heater, 240 V

Water separator with heater

Dust net

Reversible fan

Air inlet turbo precleaning system

Micro- mesh and sealing for engine compartment

Tropical cooling

Waste package

Electric / Electronic control system

Travel alarm

Rotating beacon

Extra work lights: (LED or halogen)

Service walkway 1 and counterweight 1

Boom-mounted 2

Cab front 2

Extra LED lights on arm and Cab (4)

Multi-channel electric centre passage

Anti-theft system

Tilting and rotating attachment preparation

Hydraulic system

Boom float function

Hydraulic oil, biodegradable ISO VG 32

Hydraulic oil, biodegradable ISO VG 46

Hydraulic long life oil ISO VG 32

Hydraulic long life oil ISO VG 68

Hydraulic equipment for:

Hammer & shears

Slope bucket/rotator

Grab/clam shell

Quick fit

Flow control

Flow & pressure control

Boom suspension system

Cab and interior

Volvo Care Cab with openable PC roof hatch / ROPS

Tiltrotator Joystick

Proportional control joystick

On/off joystick

Falling object guard (FOG)

Cab mounted falling object protective structures (FOPS)

Rain shield, front

Side camera

Steelwrist tiltrotator preparation

Volvo Smart View system

Safety net for front window

Lower wiper

Ashtray

Lighter

Seat:

Mechanical Fabric seat, with/or without heater

Airsuspension seat with heater and X isolator

Luxury operator seat with aico and wide armrest

OPTIONAL EQUIPMENT

Undercarriage

Twin tires 10.00 - 20 / 11.00 - 20

Single tires 18R - 19.5 / 620/40-22.5

Stone protection rings

Solid rubber tires 10.00-20/11.00-20

Front dozer blade and rear outriggers

Rear dozer blade

Front outriggers and rear dozer blade

Grab holder

Mudguards, front/rear

Tool box, left hand side/right hand side

Cruise control

Travel speed 20 km/h, 30 km/h, 35 km/h

Trailer Towing system

Automatic digging brake

Drawer type Toolbox

Digging equipment

Booms

4.5 m mono boom

4.7 m 2-piece boom

4.75 m mono offset boom

Dipper arms

2.0 m, 2.45 m, 2.6 m, 3.1 m

Hydraulic quick fit

S60 system

Universal system

Attachments

Buckets, direct fit and for Quick Couplers:

General Purpose bucket (GP)

Heavy Duty bucket

Lifting eye

Tiltrotator Steelwrist

Service

Tool kit, daily maintenance

Automatic Greasing System

Wheel chocks

Superstructure

License plate preparation

SELECTION OF VOLVO OPTIONAL EQUIPMENT

Trailer hitch**Boom suspension****LED working lights****Automatic greasing****Automatic digging brake****Tiltrotator joystick and monitor**

Not all products are available in all markets. Under our policy of continuous improvement, we reserve the right to change specifications and design without prior notice. The illustrations do not necessarily show the standard version of the machine.

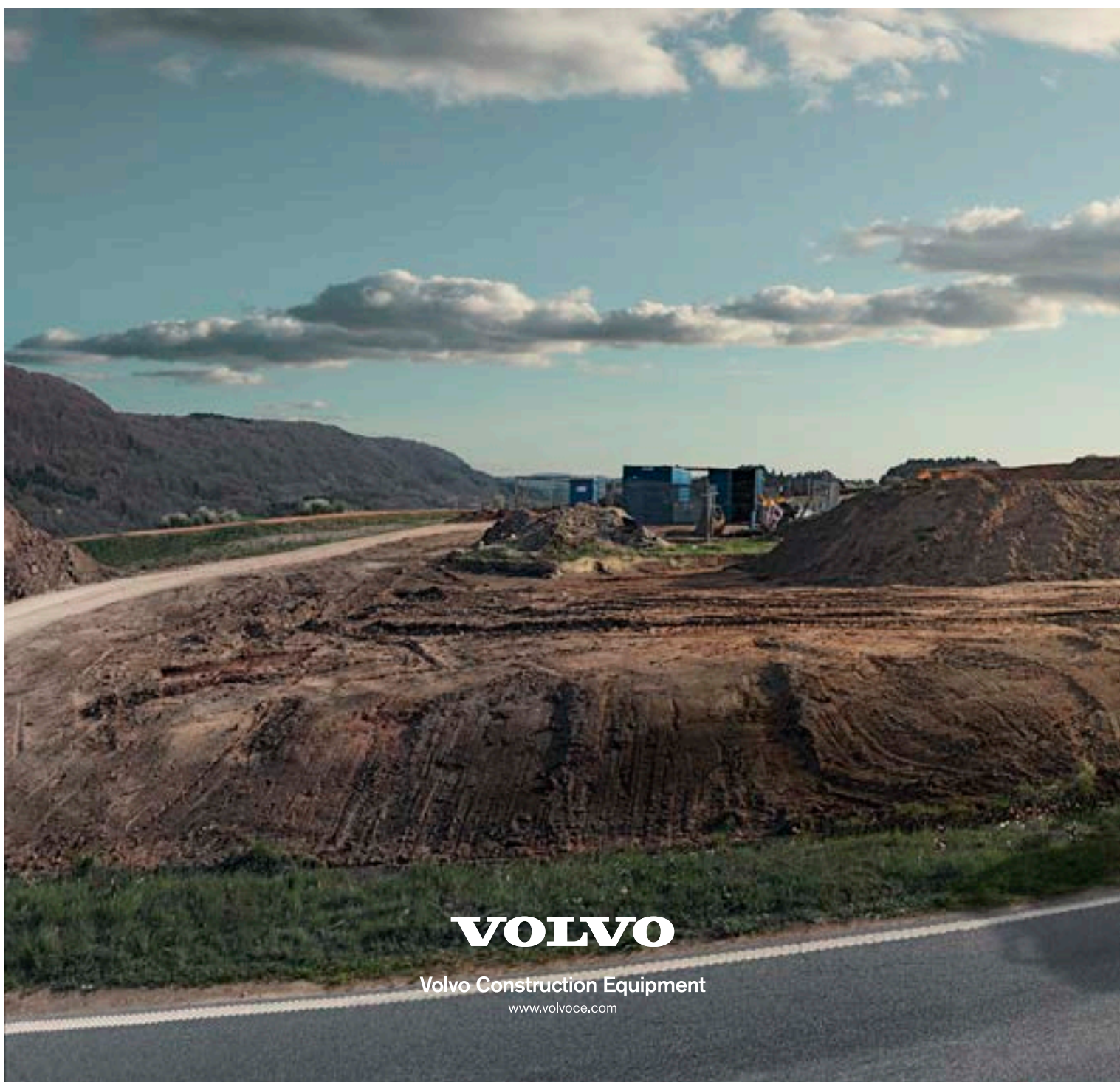

VOLVO

Volvo Construction Equipment

www.volvoce.com