



**JCB 532-120**

**LOADALL**



**3.2 TONNES TO 12 METRES LIFT HEIGHT.**

# GENERAL SPECIFICATION

## STATIC DIMENSIONS

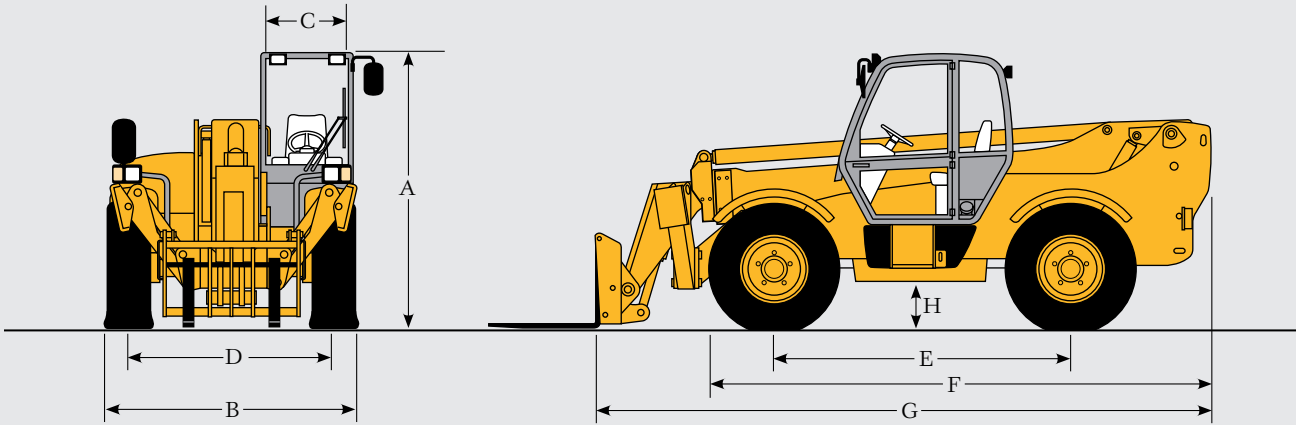

<b>A</b> Overall height	2.59m	8' 6"
<b>B</b> Overall width (over tyres)	2.35m	7' 9"
<b>C</b> Inside width of cab	0.94m	3' 1"
<b>D</b> Front track	1.90m	6' 3"
<b>E</b> Wheelbase	2.75m	9' 0"
<b>F</b> Overall length to front tyres	4.83m	15' 10"
<b>G</b> Overall length to front carriage	5.84m	19' 2"
<b>H</b> Ground clearance	0.40m	1' 4"

Width over fully extended stabilizers	2.73m	8' 11"
Overall length to stabilizers – retracted	5.39m	17' 8"
Overall length to stabilizers – extended	5.42m	17' 10"
Outside turn radius (over tyres)	4.0m	13' 2"
Departure angle	35°	
Weight	9140kg	20150lb
Tyres	15.5/80-24	

## PERFORMANCE

### WITH STABILISERS EXTENDED

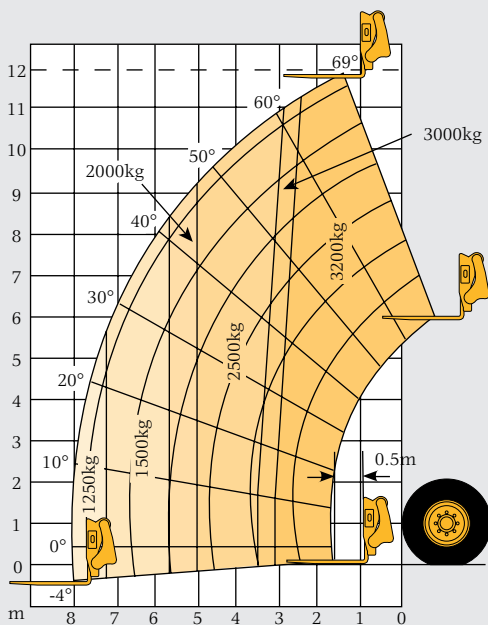

Maximum lift capacity	3200kg	7055lb
Lift capacity to full height	3200kg	7055lb
Lift capacity at full reach	1250kg	2756lb
Lift height	12.0m	39' 4"
Reach at maximum lift height	1.44m	4' 9"
Maximum forward reach	8.0m	26' 3"
Reach with 1 tonne load	8.0m	26' 3"
Placing height	11.42m	37' 6"

Complies with FEM stability test 4.001R

### CHASSIS LEVELLING (SWAY)\* WITH STABILISERS RETRACTED (SWAY ANGLE ±9°)

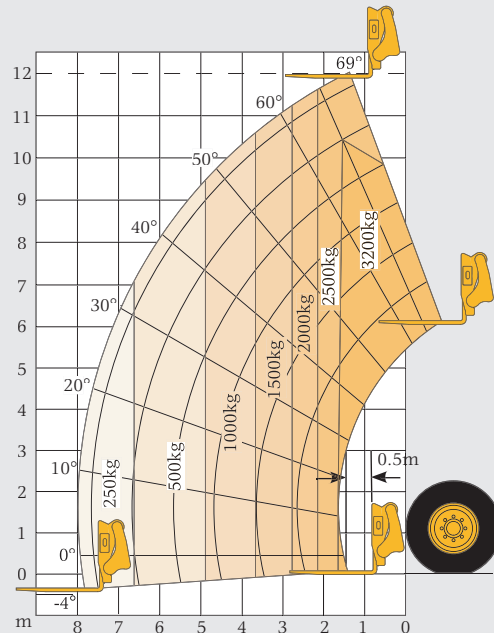

Maximum lift capacity	3200kg	7055lb
Lift capacity to full height	2500kg	5512lb
Lift capacity at full reach	250kg	551lb
Lift height	12.0m	39' 4"
Reach at maximum lift height	1.44m	4' 9"
Maximum forward reach	8.0m	26' 3"
Reach with 1 tonne load	4.89m	16' 0"
Placing height	11.42m	37' 6"

Complies with FEM stability test 4.001R

\*Factory fitted option.

# JCB 532-120 LOADALL

# GENERAL SPECIFICATION

## ENGINE

4 cylinders. Bore 103mm (4.06in); stroke 127mm (5in); displacement 4.20ltr (256in<sup>3</sup>).

Latest technology and advanced design provides low fuel consumption, reduced noise, high torque and power output, total reliability and minimal maintenance.

Easily replaceable pre-finished dry liners, five bearing, heat treated crankshaft. Expansion controlled pistons. Two-stage, dry type air filter with primary and safety elements, and pre cleaner.

Engine conforms with EC mobile off-highway emissions regulations (stage 1).

### Engine options

Power at 2200rpm  
59.7kW (80hp) Naturally Aspirated  
Torque at 1400rpm  
290Nm (213.8lb/ft)

Power at 2200rpm  
76.1kW (102hp) Turbo Charged  
Torque at 1400rpm  
411Nm (303.1lb/ft)

## TRANSMISSION

JCB 4 speed powershift transmission incorporating torque converter, bevel box and a 4 speed powershift gearbox in one resiliently mounted unit.

A combined steering column mounted switch incorporating directional control and 4 forward and reverse powershift gears.

Travel speed 25km/h (15.5mph).

### Front and rear drive axles

JCB epicyclic hub reduction drive/steer axles with Max-Trac torque proportioning differentials. Permanent 4 wheel drive

## BRAKES

### Service brakes servo assisted

Hydraulically activated, self-adjusting, oil-immersed in-board multi-disc type in front axle and rear axle.

### Parking brake

Hand operated disc brake on output of gearbox.

## BOOM AND CARRIAGE

Boom is manufactured from high tensile steel.

Low maintenance, hard wearing pads.

JCB Q-fit self-levelling carriage with lever operated pin locking accepts pallet forks and a wide range of attachments.

## SERVICE CAPACITIES

Fuel tank	125ltr (27.5gal)
-----------	------------------

Hydraulic tank	131ltr (28.8gal)
----------------	------------------

Coolant	23ltr (5.1gal)
---------	----------------

## HYDRAULICS

Single gear pump, with suction strainer and filter.

Operating system pressure:  
241 bar (3500 psi).

Flow at system pressure  
(at 2200 rpm) – 110ltr/min.

Cycle times (secs)	
--------------------	--

Boom raise	9.9
------------	-----

Boom lower	7.6
------------	-----

Extend	13.0
--------	------

Retract	13.7
---------	------

Bucket dump	2.2
-------------	-----

Bucket crowd	2.9
--------------	-----

## SAFETY CHECK VALVES

Fitted to carriage tilt, telescopic and boom lift rams.

Stabilizer legs and chassis levelling rams fitted with check valves on rod and head side, plus cut-out system to disconnect movement when boom is raised.

## ELECTRICS

12 v negative earth.

92 AH battery.

65 amp alternator.

Full road lighting.

Reversing light.

Direction indicators.

Hazard warning.

Reverse alarm.

## CAB

Quiet safe and comfortable cab conforms to ROPS ISO 3471 and FOPS ISO 3449. Tinted glass all round with laminated roof screen. Roof bars, front, rear and roof screen wash/wipe and heater/screen demister. Opening rear window. Audio-visual warning system for coolant temperature, engine oil pressure, air cleaner, battery charge, transmission oil temperature and pressure. Hourmeter, road speed and inclinometer.

Engine temperature and fuel gauge.

Mechanical joystick, direct acting hydraulic control levers. Adjustable steer column incorporates stalk bar powershift change and forward reverse shuttle. Throttle, brake pedal floor mounted. Adjustable suspension seat with adjacent park brake.

Automatic eye level audio-visual load moment indicator warning system receiving a signal from a load sensor on the rear axle.

This system continuously monitors the machine's forward stability and leaves the operator in control at all times.

Optional indicator lamp to show when the stabilizers are on firm ground.

Safety canopy as above but with side glass and roof glass only (screen wiper and heater/screen demister not applicable).

## STEERING

Three steer mode options: front wheel steer; all wheel steer; crab steer: operated from in the cab by a selection switch with automatic alignment.

## OPTIONS AND ACCESSORIES

**Options:** Front and rear working lights, rotating flashing beacon, fire extinguisher, industrial tyres, electrical 2/4WD disconnect, windscreen guard, load guard, pre-cleaner bowl or centrifugal type, suspension seat, air suspension seat, deluxe cab trim, roof blind, radio kit, heavy duty battery, air conditioning, sway chassis and boom end auxiliary service.

**Attachments:** Contact your local dealer for details of the comprehensive range.





# A GLOBAL COMMITMENT

# TO QUALITY.

JCB's total commitment to its products and customers has helped it grow from a one-man business into Britain's largest privately owned manufacturer of backhoe loaders, crawler excavators, wheeled excavators, telescopic handlers, wheeled loaders, rough terrain fork lifts, industrial fork lifts, mini excavators, skid steers and tractors.

By making constant and massive investments in the latest production technology, the JCB factories have become some of the most advanced in Europe.

By leading the field in innovative research and design, extensive testing and stringent quality control, JCB machines have become renowned all over the world for performance, value and reliability.

And with a global sales and service network of over 400 distributors and agents, the company exports over 70% of its production to all five continents.

Through setting the standards by which others are judged, JCB has become one of Britain's most impressive success stories.



JCB care for the environment.  
This paper has been produced without  
the use of elemental chlorine chemicals  
in the bleaching process.

JCB Sales Limited, Rocester, Staffordshire ST14 5JP.  
Tel: 01889 590312. Fax: 01889 590588.  
Web: <http://www.jcb.co.uk>

JCB reserves the right to change specifications without notice.  
Illustrations shown may include optional equipment and accessories.

9999/4617 1/02

